



Ultralite Supercoat MDF Mouldings

• **WEIGHT SIMILAR TO PINE**

Ultralite Supercoat mouldings have a similar density and weight to Ponderosa Pine.

• **NO GRAIN-RAISE, FINGER JOINTS OR KNOTS**

Will not show defects that are often visible with paint-grade pine - such as open joints (finger joints and edge glued), and grain-raise.

• **BETTER WORKABILITY THAN OTHER MDF MOULDINGS**

Ultralite mouldings cut, cope, miter, and staple better than most other MDF mouldings, and will not "volcano" when nailing.

• **SUPERB PRIME COATING**

Finished with a unique two-coat process that gives a superior primed top coat.

• **EXCELLENT DIMENSIONAL STABILITY**

Will not twist or split like natural wood.

• **COMPETITIVE PRICING**

Stable price below primed finger joint mouldings.

Create Your Own Custom Look

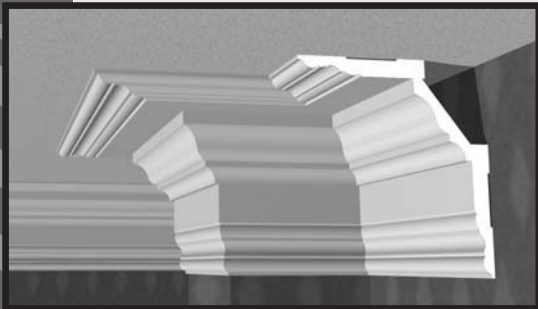

The moulding at the top of the ceiling is:
MOULDING & MILLWORK #412 Baseboard

The angled moulding is:
MOULDING & MILLWORK #47 Crown

The moulding mounted on the wall is:
MOULDING & MILLWORK #412 Baseboard

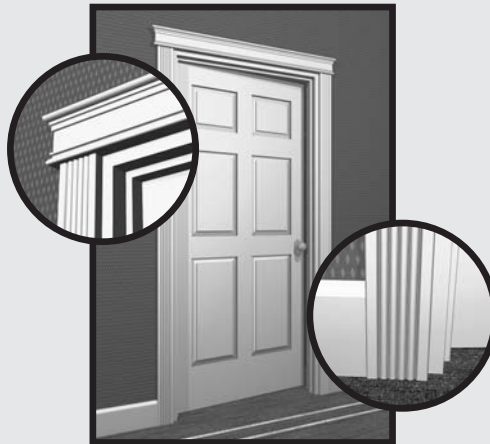

The architrave moulding at the top of the door is:
MOULDING & MILLWORK #RB3

The door casing is:
MOULDING & MILLWORK #908

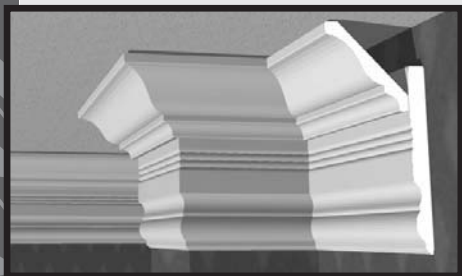

The angled moulding is:
MOULDING & MILLWORK #47 Crown
The moulding mounted on the wall is:
MOULDING & MILLWORK #8263 Baseboard

Table of Contents

- 1 Ultralite Supercoat
- 2 Illustration
- **Solid Pine & Primed FJ**
 - 4 Casings
 - 5 Baseboards
 - 6 Crowns
 - 7 Door Stops & Battens
 - 8 Brickmoulds & Lattice
 - 8 Chair Rails
 - 9 Panel Mouldings
 - 9 Half Rounds, Quarter Rounds & Shoes
 - 10 Covs
 - 10 Corners
 - 10 Hand & Wall Rails
 - 11 Misc. Profiles
- **Oak & Poplar**
 - 14 Casings
 - 19 Baseboards
 - 21 Crowns
 - 21 Door Stops & Battens
 - 22 Chair Rails
 - 22 Panel Mouldings
 - 23 Lattice
 - 23 Quarter Rounds & Shoes
 - 23 Covs
 - 24 Mullions
 - 24 Corners
 - 24 Hand & Wall Rails
 - 25 Misc. Profiles
- **Ultralite MDF**
 - 25 Casings
 - 27 Baseboards
 - 29 Crowns
 - 31 Chair Rails
- **PVC**
 - 31 Brickmoulds
- **FIR**
 - 31 Squares
 - 31 Hand & Wall Rails
 - 32 Misc. Profiles
- 32 Finish Boards (S4S)
- 32 Interior Jambs
- 33 Glossary of Terms

The Best Source for Mouldings, S4S Boards and Jambs

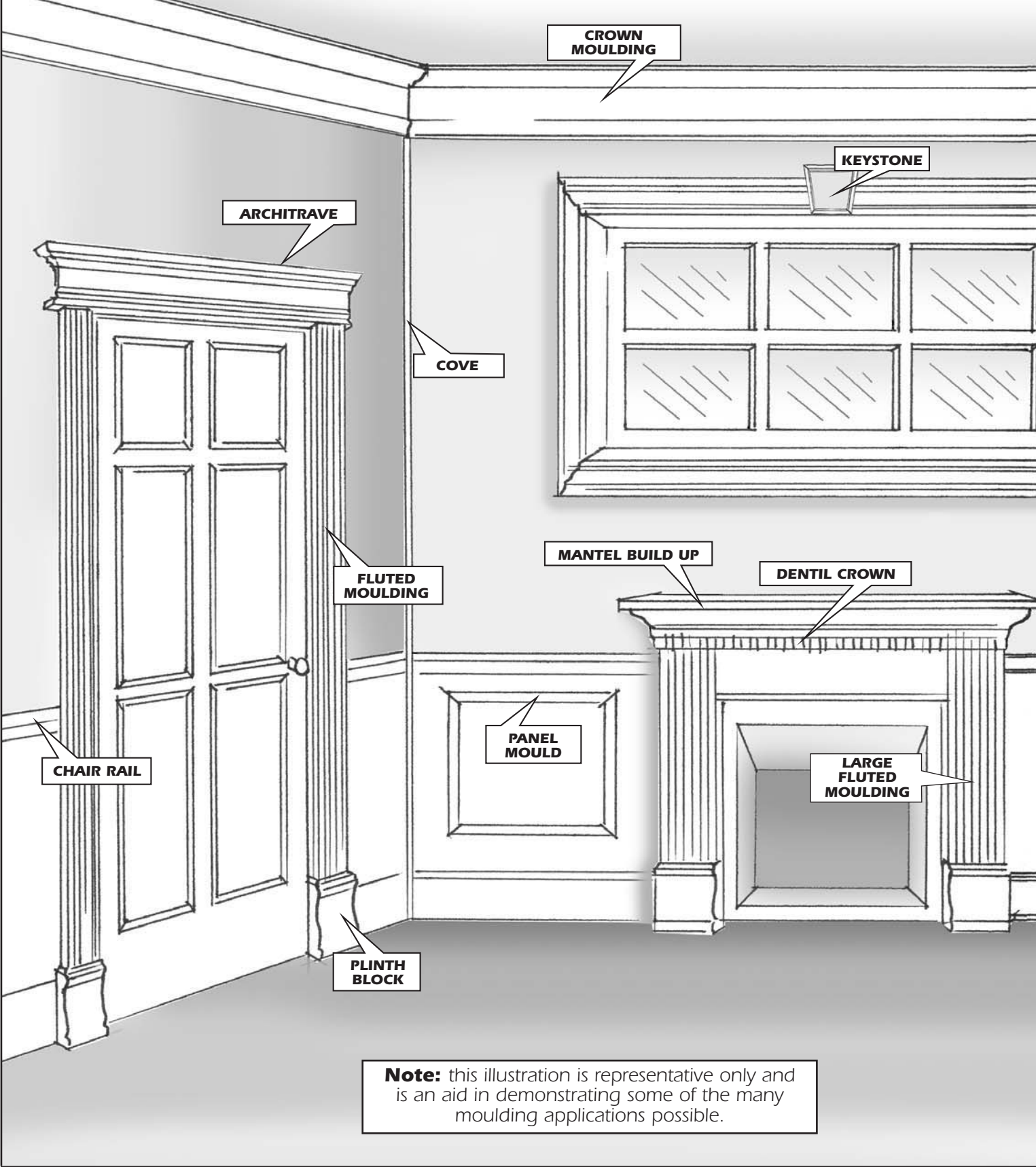

MOULDING & MILLWORK

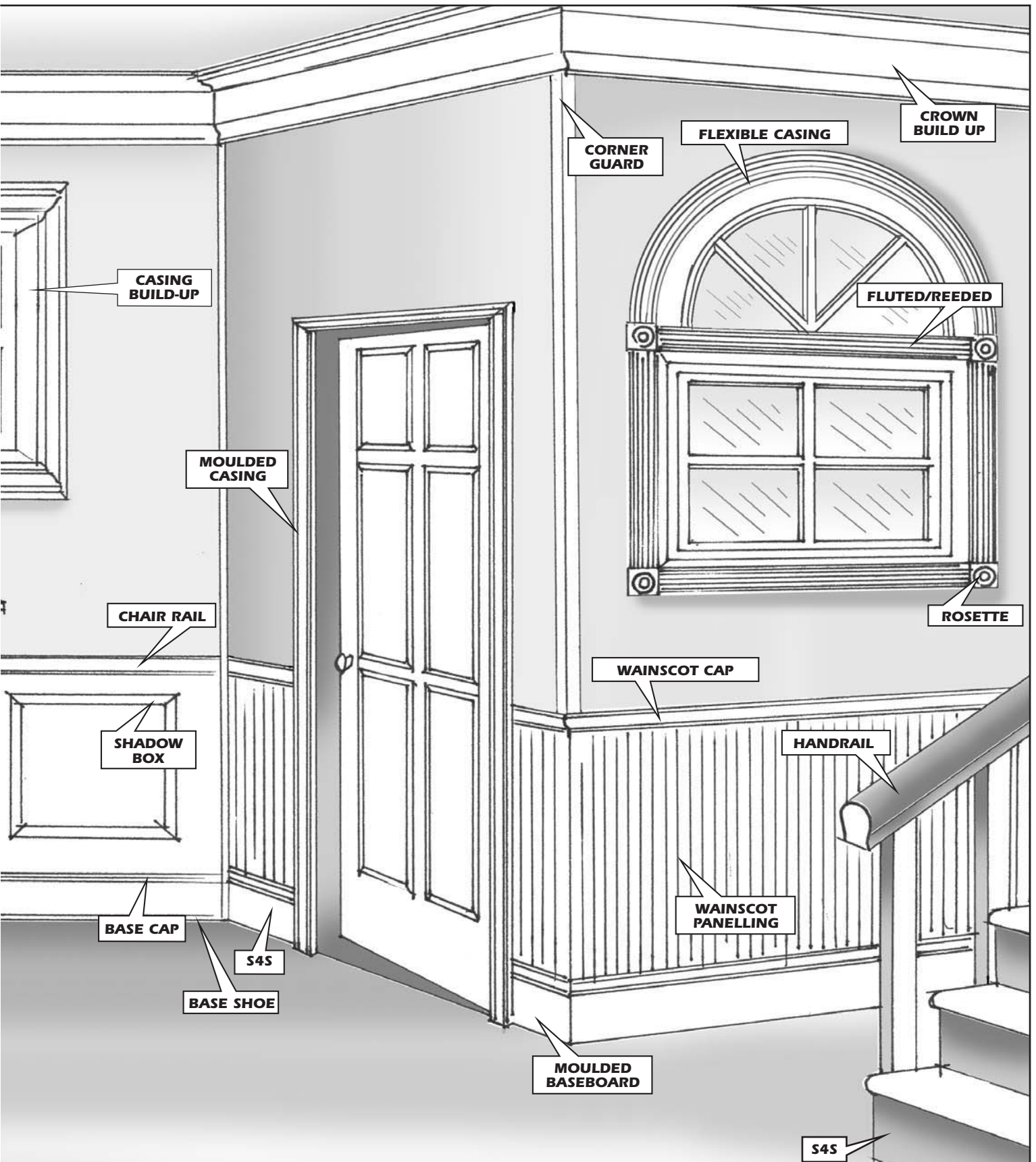

Casings - SOLID PINE & PRIMED FJ

Casings define the overall character of a room and are often the most visible part of the trim. They are used primarily to cover the gap between drywall and the door or window frame. Casings are generally thicker than the base mouldings.

ALL SIZES NOMINAL

M&M#	WM#	Fluted/Reeded	
37	37	9/16" x 3-1/4"	Solid Pine
37P	37P	9/16" x 3-1/4"	Primed FJ



M&M#	WM#	Ranch	
316	316	11/16" x 2-1/4"	Solid Pine
327	327	11/16" x 2-1/4"	Solid Pine
327P	327P	11/16" x 2-1/4"	Primed FJ

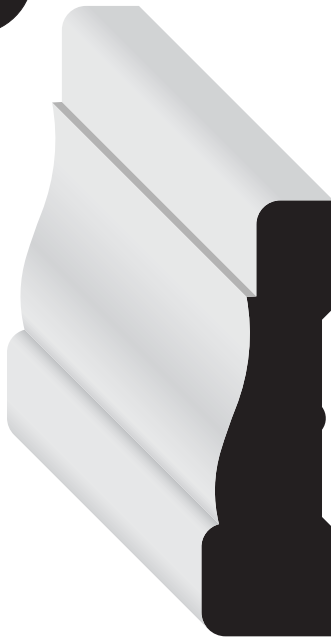

M&M#	WM#	Colonial	
351	351	11/16" x 2-1/2"	Solid Pine
356	356	11/16" x 2-1/4"	Solid Pine
356P	356P	11/16" x 2-1/4"	Primed FJ

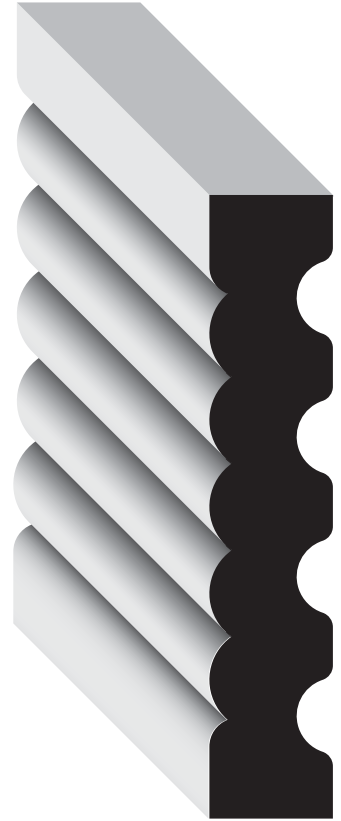

M&M#	WM#	Colonial Feather Edge	
361	361	11/16" x 2-1/2"	Solid Pine
361W	361	11/16" x 3-1/2"	Solid Pine
361P	361	11/16" x 2-1/2"	Primed FJ
361WP	361	11/16" x 3-1/2"	Primed FJ

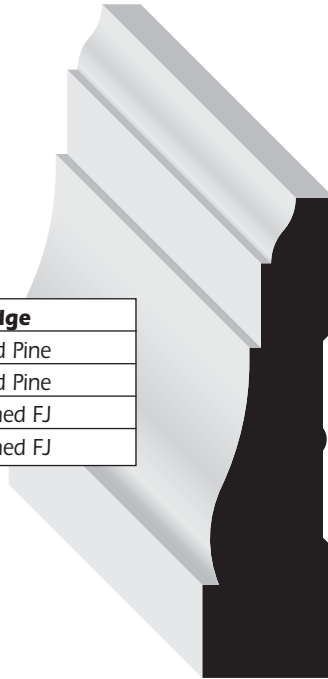

M&M#	WM#	Beaded	
376	376	11/16" x 2-1/4"	Solid Pine
376P	376P	11/16" x 2-1/4"	Primed FJ
445	445	11/16" x 3-1/4"	Solid Pine
445P	445P	11/16" x 3-1/4"	Primed FJ



M&M#	WM#	Colonial	
444	444	11/16" x 3-1/2"	Solid Pine
444P	444P	11/16" x 3-1/2"	Primed FJ

Baseboards - SOLID PINE & PRIMED FJ

Baseboards are placed along the wall at the floor. They should be chosen to work in harmony with your casings to finish and tie the room together. Baseboards are usually thinner than the casing.

ALL SIZES NOMINAL

M&M#	WM#	Speed Base	
163E	163	11/16" x 5-1/4"	Solid Pine
163EP	163	11/16" x 5-1/4"	Primed FJ

M&M#	WM#	O.G.	
618	618	9/16" x 5-1/4"	Solid Pine
618P	618	9/16" x 5-1/4"	Primed FJ
620	620	9/16" x 4-1/4"	Solid Pine
620P	620	9/16" x 4-1/4"	Primed FJ
622	622	9/16" x 3-1/2"	Solid Pine
622P	622	9/16" x 3-1/2"	Primed FJ
623	623	9/16" x 3-1/4"	Solid Pine
623P	623	9/16" x 3-1/4"	Primed FJ
624	624	9/16" x 3"	Solid Pine
624P	624	9/16" x 3"	Primed FJ
634SP	634	7/16" x 3"	Primed FJ

M&M#	WM#		
750	750	9/16" x 4-1/4"	Solid Pine
750P	750	9/16" x 4-1/4"	Primed FJ

M&M#	WM#		
660	660	9/16" x 4-1/4"	Solid Pine
662	662	9/16" x 3-1/2"	Solid Pine
662P	662	9/16" x 3-1/2"	Primed FJ
663	663	9/16" x 3-1/4"	Solid Pine
663P	663	9/16" x 3-1/4"	Primed FJ

M&M#	WM#		
664	664	9/16" x 3"	Solid Pine
664P	664	9/16" x 3"	Primed FJ

M&M#	WM#	Tear Drop	
713	713	9/16" x 3-1/4"	Solid Pine
713P	713	9/16" x 3-1/4"	Primed FJ
714	714	9/16" x 3"	Solid Pine
714P	714	9/16" x 3"	Primed FJ

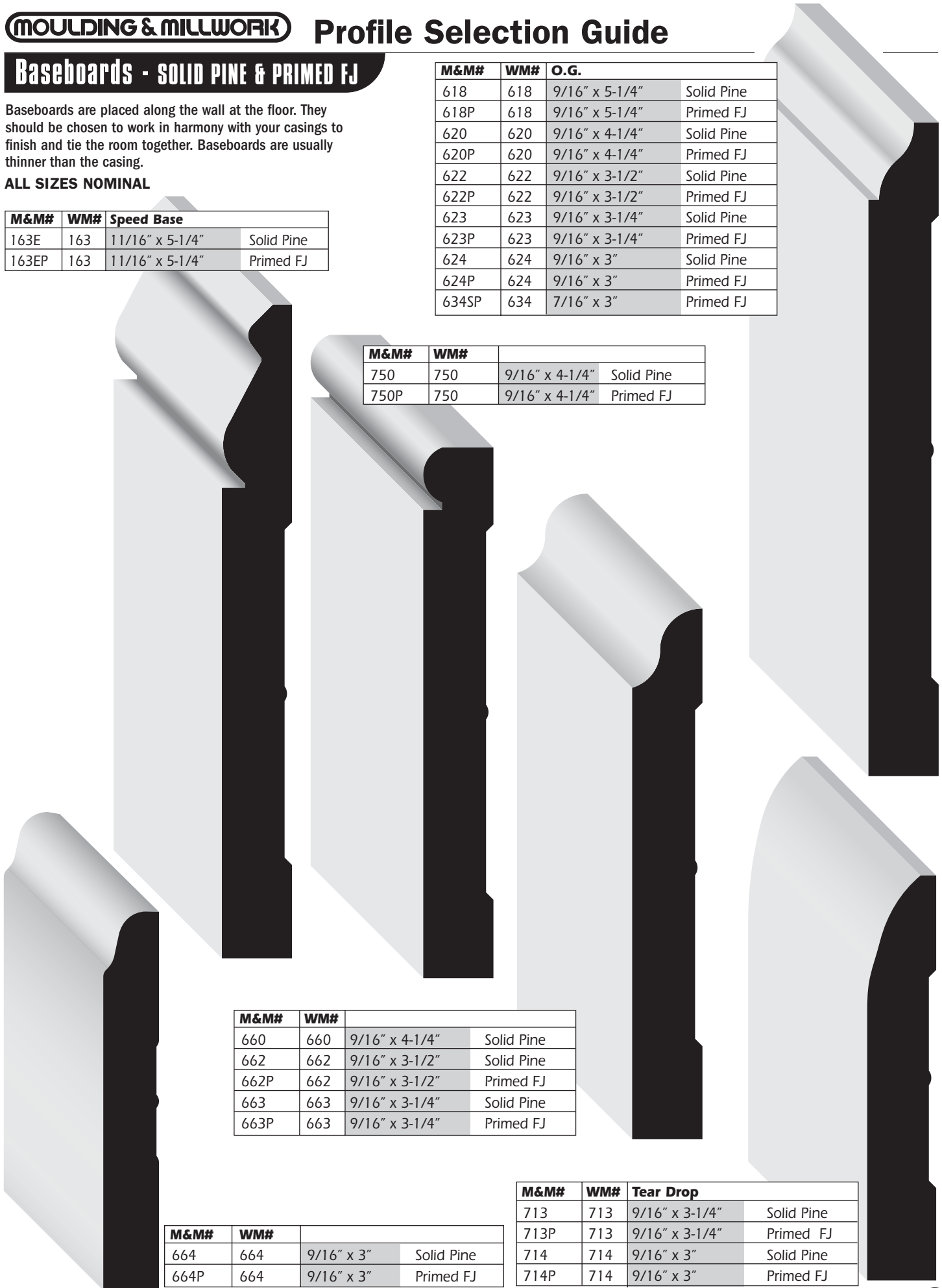

Crowns - SOLID PINE & PRIMED FJ

Crowns are placed along the wall at the ceiling. They come in a wide range of patterns and sizes. Crowns soften the transition from wall to ceiling while adding a distinctive look and charm to your room.

ALL SIZES NOMINAL

M&M#	WM#	Crown	
49	49	9/16" x 3-5/8"	Solid Pine
49P	49P	9/16" x 3-5/8"	Primed FJ

M&M#	WM#	Crown	
45	45	1 1/16" x 5-1/4"	Solid Pine
45P	45P	1 1/16" x 5-1/4"	Primed FJ

M&M#	WM#	Crown	
47	LWM47	9/16" x 4-5/8"	Solid Pine
47P	47	9/16" x 4-5/8"	Primed FJ

M&M#	WM#	Crown	
68	68	9/16" x 1-5/8"	Solid Pine

M&M#	WM#	Dentil	
44	44	1 1/16" x 4-1/4"	Solid Pine
44P	44P	1 1/16" x 4-1/4"	Primed FJ

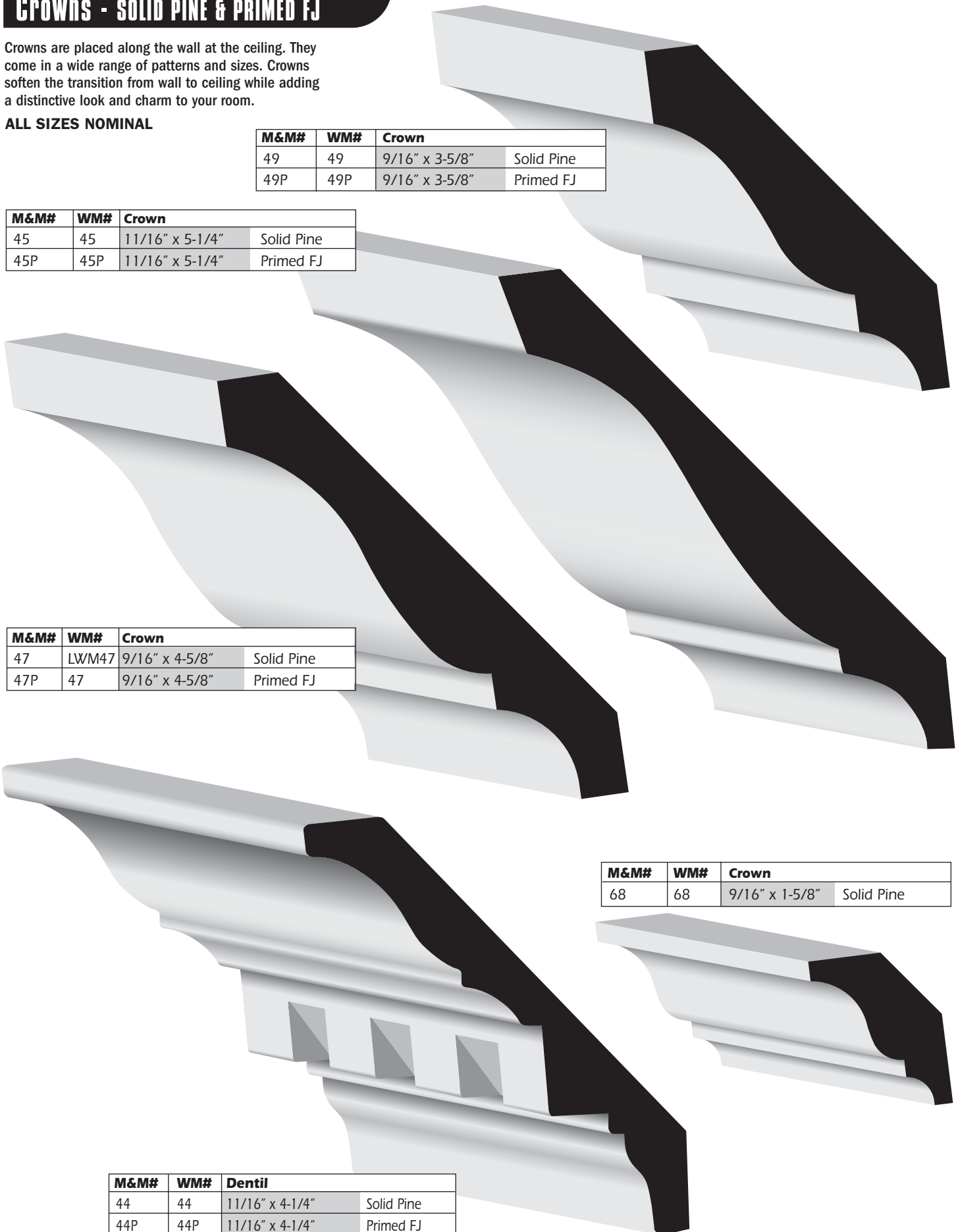

Crowns - SOLID PINE & PRIMED FJ

Crowns are placed along the wall at the ceiling. They come in a wide range of patterns and sizes. Crowns soften the transition from wall to ceiling while adding a distinctive look and charm to your room.

ALL SIZES NOMINAL

M&M#	WM#	Crown	
52	52	9/16" x 2-3/4"	Solid Pine



M&M#	WM#	Crown	
53	53	9/16" x 2-5/8"	Solid Pine
53P	53P	9/16" x 2-5/8"	Primed FJ

M&M#	WM#	Crown	
54	54	9/16" x 2-1/4"	Solid Pine

Door Stops & Battens - SOLID PINE & PRIMED FJ

Stops are attached to the door jamb on both sides and at the top. It is where the door comes to a rest when it is closed stopping the door from moving any further, and covering the gap that would otherwise appear between the door and the jambs.

ALL SIZES NOMINAL

M&M#	WM#	Colonial	
946	946	3/8" x 1-3/8"	Solid Pine
946P	946P	3/8" x 1-3/8"	Primed FJ

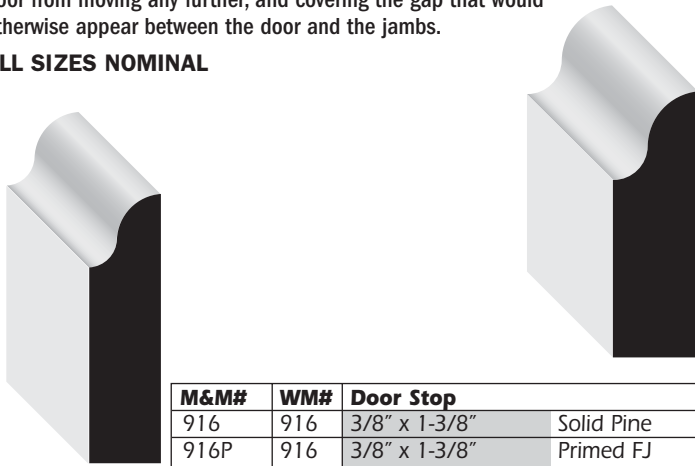
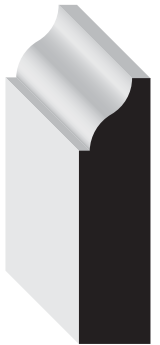

M&M#	WM#	Door Stop	
916	916	3/8" x 1-3/8"	Solid Pine
916P	916	3/8" x 1-3/8"	Primed FJ

M&M#	WM#	Door Stop	
906	906	7/16" x 1-3/8"	Solid Pine



M&M#	WM#	Colonial	
947	947	3/8" x 1-1/4"	Solid Pine

M&M#	WM#	Round Edge	
885	885	3/8" x 1-5/8"	Solid Pine
886	886	3/8" x 1-3/8"	Solid Pine
886P	886	3/8" x 1-3/8"	Primed FJ



M&M#	WM#	Tear Drop	
856	856	3/8" x 1-3/8"	Solid Pine
856P	856	3/8" x 1-3/8"	Primed FJ

Brickmoulds & Lattice - SOLID PINE & PRIMED FJ

BRICKMOULDS: A Brickmould is used as exterior casing around doors. 2 inches is the most common size, however, 1-1/2 and 1-1/4 inch sizes are available.

LATTICE: Lattice is a thin strip of flat moulding commonly used to hide seams and trim edges. It is available in a multitude of widths and are useful for a wide variety of projects

ALL SIZES NOMINAL

M&M#	WM#	Lattice	
265	265	1/4" x 1-3/4"	Solid Pine
267	267	1/4" x 1-3/8"	Solid Pine
268	268	1/4" x 1-1/8"	Solid Pine

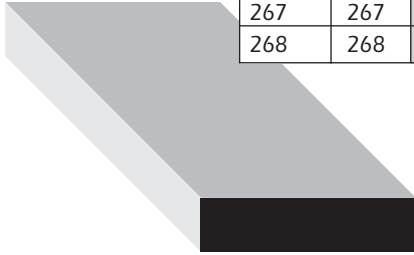

M&M#	WM#	Brickmould	
180	180	1-1/4" x 2"	Solid Pine
180P	180	1-1/4" x 2"	Primed FJ

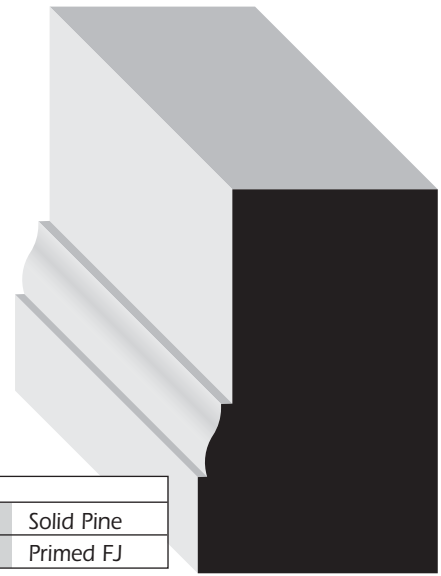

Chair Rails - SOLID PINE & PRIMED FJ

Chair Rails are practical as well as decorative. Applied to a wall, anywhere from 24 to 48 inches from the floor, they protect the wall from scuffs and dents from the backs of chairs as well as adding a beautiful accent to any room.

ALL SIZES NOMINAL

M&M#	WM#	Chair Rail	
300	300	1-1/16" x 3"	Solid Pine
300P	300	1-1/16" x 3"	Primed FJ

M&M#	WM#	Chair Rail	
301	301	1-1/16" x 3-3/8"	Solid Pine

M&M#	WM#	Chair Rail	
390	390	1 1/16" x 2-5/8"	Solid Pine
390P	390	1 1/16" x 2-5/8"	Primed FJ



M&M#	WM#	Chair Rail	
297	297	1 1/16" x 3"	Solid Pine
297P	297	1 1/16" x 3"	Primed FJ

M&M#	WM#	Chair Rail-Rabbeted	
77	77	9/16" x 2-1/4"	Solid Pine

Panel Mouldings - SOLID PINE & PRIMED FJ

Panel moulds are used to frame wall paneling and add a decorative element to this type of application. Panel moulds also add accent to walls.

ALL SIZES NOMINAL

M&M#	WM#		
163	163	11/16" x 1-3/8"	Solid Pine
163P	163	11/16" x 1-3/8"	Primed FJ

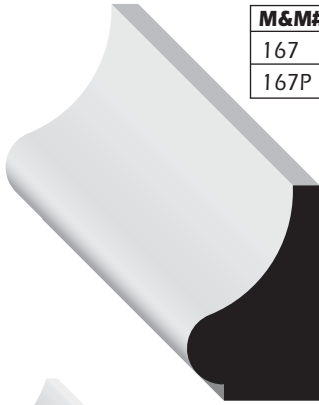

M&M#	WM#	Bed/Base Cap	
167	167	11/16" x 1-1/8"	Solid Pine
167P	167	11/16" x 1-1/8"	Primed FJ

M&M#	WM#	Base Cap	
166	166	11/16" x 1-1/4"	Solid Pine
166P	166	11/16" x 1-1/4"	Primed FJ

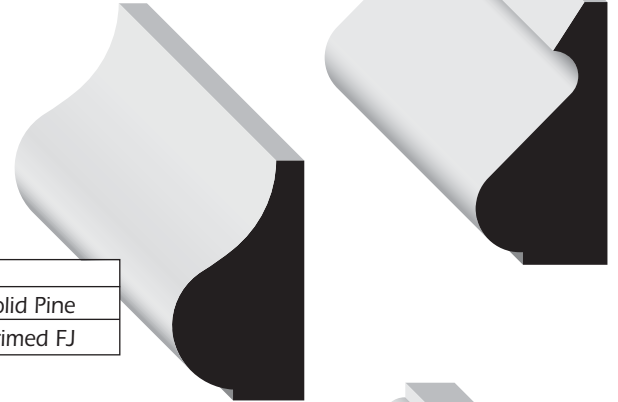

M&M#	WM#	Panel	
173	173	1/4" x 1-3/8"	Solid Pine

M&M#	WM#	Panel	
186	LWM186	3/8" x 1-1/8"	Solid Pine

M&M#	WM#	Panel	
133	133	1/16" x 1-3/4"	Solid Pine

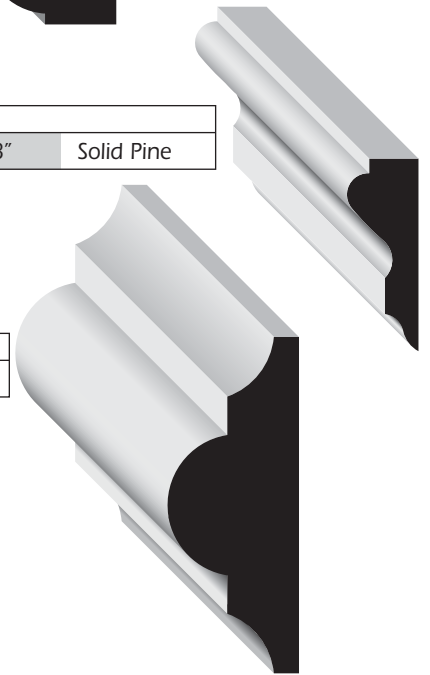

M&M#	WM#	Panel	
989	989	3/8" x 1-5/8"	Solid Pine

Half Rounds, Quarter Rounds & Shoes - SOLID PINE & PRIMED FJ

Half Rounds: A cross section of this profile looks like a half circle and is used primarily as decorative trim.

Quarter Rounds come in several sizes and serve a variety of functions. However, they are most often used to finish inside corners.

Shoes are primarily used to trim flooring materials and are often used in combination with a traditional baseboard to conceal variations between the flooring and the base.

ALL SIZES NOMINAL

M&M#	WM#	Half Round	
120	120	1/2" x 1"	Solid Pine
123	123	5/16" x 5/8"	Solid Pine

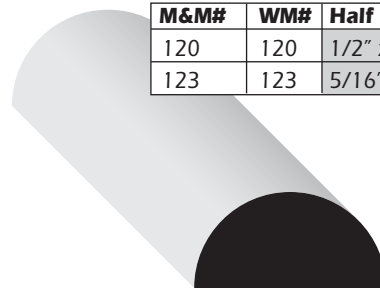

M&M#	WM#	Shoes	
126	126	1/2" x 3/4"	Solid Pine
126P	126	1/2" x 3/4"	Primed FJ
127	127	7/16" x 3/4"	Solid Pine
127P	127	7/16" x 3/4"	Primed FJ
129	129	7/16" x 11/16"	Solid Pine
129P	129	7/16" x 11/16"	Primed FJ
131	131	7/16" x 3/4"	Solid Pine

M&M#	WM#	Quarter Round	
103	103	1-1/16" x 1-1/16"	Solid Pine
105	105	3/4" x 3/4"	Solid Pine
106	106	11/16" x 11/16"	Solid Pine
106P	106	11/16" x 11/16"	Primed FJ
108	108	1/2" x 1/2"	Solid Pine
109	109	3/8" x 3/8"	Solid Pine

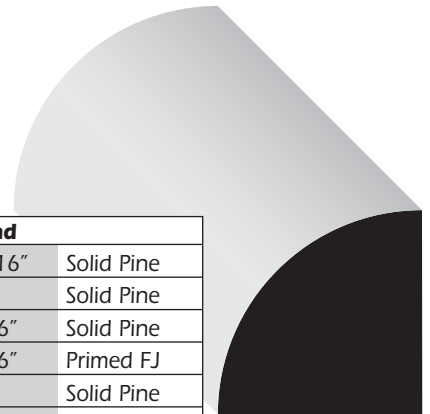

Coves - SOLID PINE & PRIMED FJ

This profile is commonly used to soften the transition on inside corners but may be used for a wide range of applications.

ALL SIZES NOMINAL

M&M#	WM#	Cove	
85	85	9/16" x 1-3/4"	Solid Pine
86	86	9/16" x 1-5/8"	Solid Pine

M&M#	WM#	Cove	
93	93	3/4" x 3/4"	Solid Pine
100	100	11/16" x 11/16"	Solid Pine
100P	100	11/16" x 11/16"	Primed FJ
101	101	1/2" x 1/2"	Solid Pine

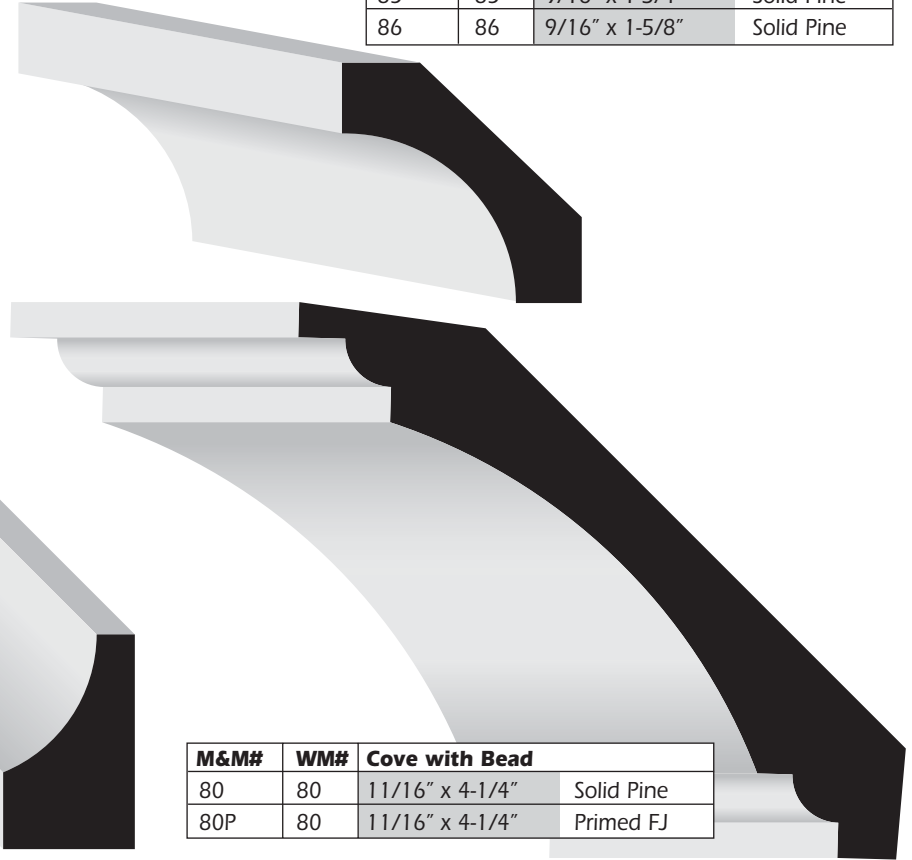

M&M#	WM#	Cove	
94	94	11/16" x 1-1/8"	Solid Pine

M&M#	WM#	Cove with Bead	
80	80	11/16" x 4-1/4"	Solid Pine
80P	80	11/16" x 4-1/4"	Primed FJ

Corners - SOLID PINE

This profile is used to protect the outside edges from damage and abrasion. Outside corners come in a wide variety of sizes and detailing.

ALL SIZES NOMINAL

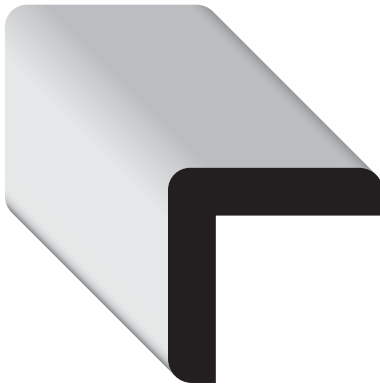

M&M#	WM#	Round Edge	
202	202	1-1/16" x 1-1/16"	Solid Pine
204	204	1-1/4" x 1-1/4"	Solid Pine
205	205	1-1/16" x 1-1/16"	Solid Pine
206	206	3/4" x 3/4"	Solid Pine

Hand & Wall Rails - SOLID PINE

Handrails provide safety and support while going up or down stairs.

ALL SIZES NOMINAL

M&M#	WM#	Round	
231R	231	1-3/8" x 1-11/16"	Solid Pine

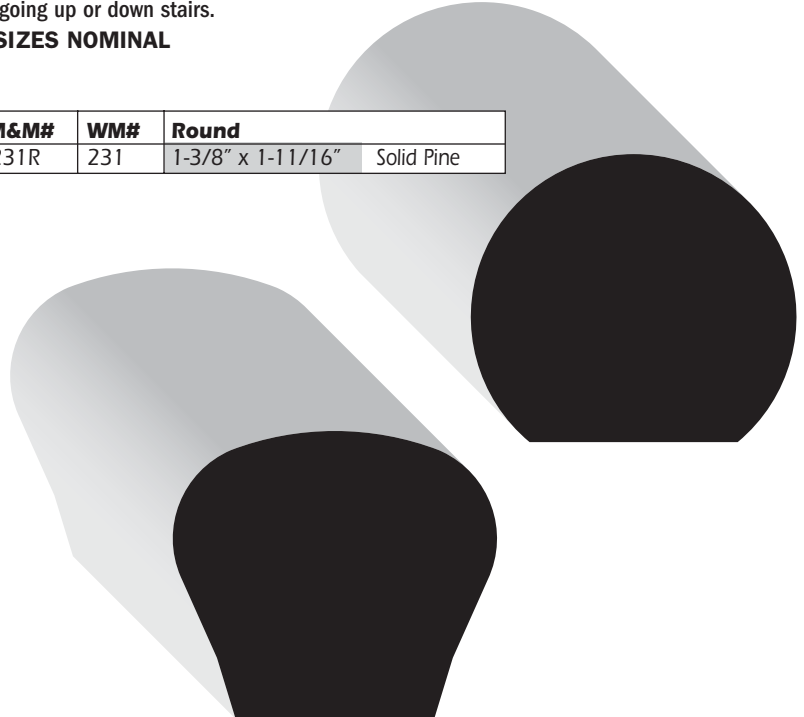

M&M#	WM#	Oval	
230R	230	1-3/8" x 1-11/16"	Solid Pine

Misc. Profiles - SOLID PINE & PRIMED FJ

ALL SIZES NOMINAL

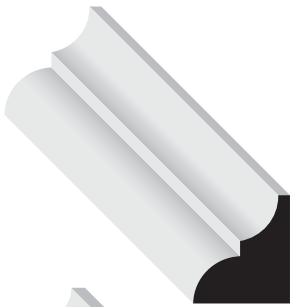

M&M#	WM#	Parting Bead	
254	254	1/2" x 3/4"	Solid Pine

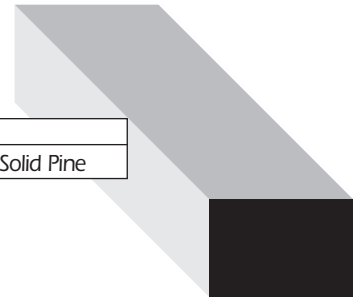

M&M#	WM#	Glass Bead	
147	147	1/2" x 9/16"	Solid Pine



M&M#	WM#	Chamfer Strip	
995	995	3/4" x 3/4"	Solid Pine



M&M#	WM#	Glass Bead	
148	148	3/8" x 3/8"	Solid Pine



M&M#	WM#	Screen Moulding Beaded	
138	138	5/16" x 5/8"	Solid Pine

M&M#	WM#	Screen Moulding Flat	
142	142	1/4" x 3/4"	Solid Pine

M&M#	WM#	Picture Moulding	
276	276	11/16" x 1-3/4"	Solid Pine

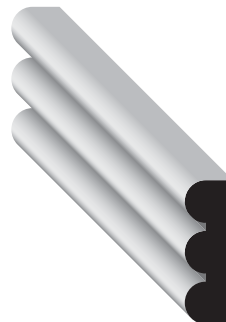

M&M#	WM#	Screen Moulding Beaded	
144	144	1/4" x 3/4"	Solid Pine

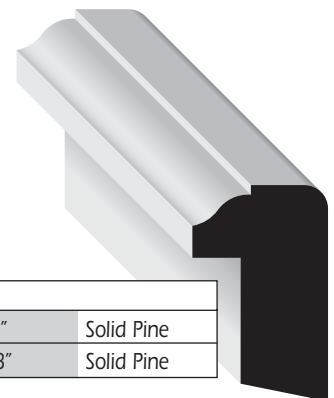
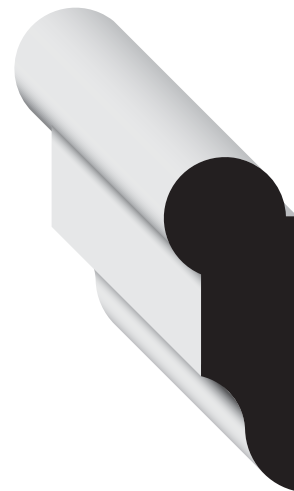

M&M#	WM#	Ply Cap	
292	292	9/16" x 1-1/8"	Solid Pine

M&M#	WM#	Back Band	
281	281	11/16" x 1-1/8"	Solid Pine
97BB	97	1-1/16" x 1-3/8"	Solid Pine

Misc. Profiles - SOLID PINE & PRIMED FJ

ALL SIZES NOMINAL

M&M#	WM#	Mullion	
958	958	3/8" x 1-1/2"	Solid Pine
972	972	3/8" x 2"	Solid Pine

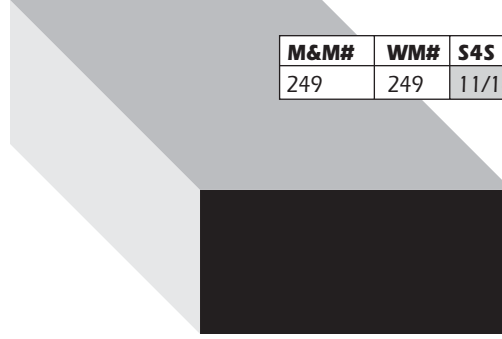

M&M#	WM#	S4S	
249	249	11/16" x 1-5/8"	Solid Pine

M&M#	WM#	Plank/Shingle	
210	210	11/16" x 1-5/8"	Solid Pine
210P	210	11/16" x 1-5/8"	Primed FJ



M&M#	WM#	Clear Pine Shingle	
207	207	11/16" x 2-1/2"	Solid Pine

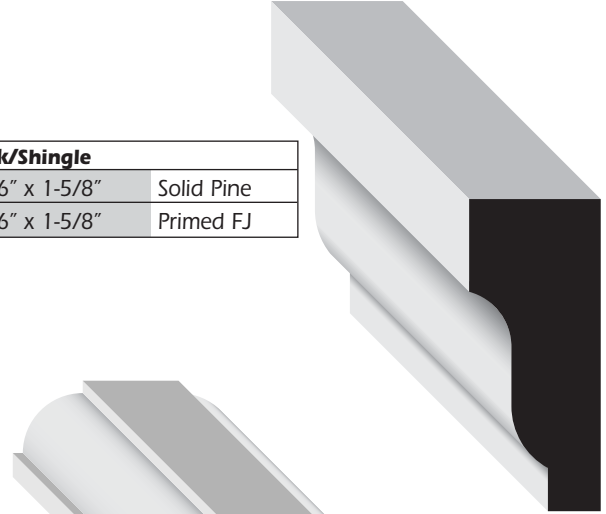

M&M#	WM#	T-Astragal	
1300-8	1300	1-3/8" Door	Solid Pine

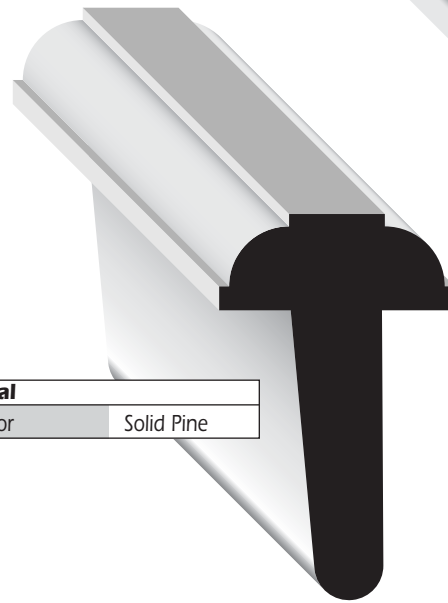

M&M#	WM#	Bed Moulding	
74	74	9/16" x 1-3/4"	Solid Pine

M&M#	WM#	Bed Moulding	
75	75	9/16" x 1-5/8"	Solid Pine
75P	75	9/16" x 1-5/8"	Primed FJ

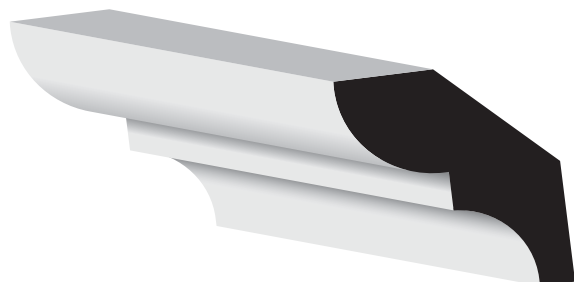
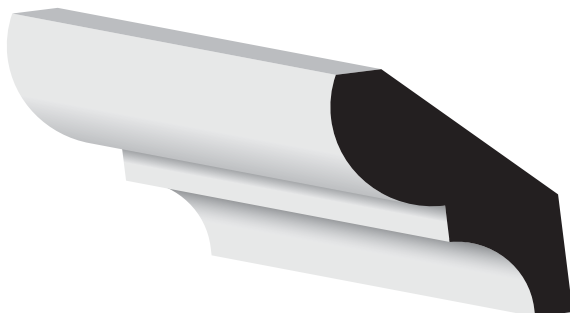

Misc. Profiles - SOLID PINE & PRIMED FJ

ALL SIZES NOMINAL



M&M#	WM#	O.G. Stool	
1197	1197	11/16" x 2-3/8"	Solid Pine

M&M#	WM#	Tilt O.G. Stool	
1197T	1197	11/16" x 2-3/8"	Solid Pine

M&M#	WM#	O.G. Stool	
1163	1163	1-1/16" x 3-1/4"	Solid Pine



M&M#	WM#	Stool	
1196	1196	11/16" x 1-15/16"	Solid Pine
1196T	1196	11/16" x 2-3/16"	Solid Pine



M&M#	WM#	Stool	
1021	1021	11/16" x 5-1/4"	Solid Pine
1021P	1021	11/16" x 5-1/4"	Primed FJ



Casings - OAK & POPLAR

Casings define the overall character of a room and are often the most visible part of the trim. They are used primarily to cover the gap between drywall and the door or window frame. Casings are generally thicker than the base mouldings.

ALL SIZES NOMINAL

M&M#	WM#		
L99O	99	3/4" x 3-1/2"	Red Oak
L99POP	99	3/4" x 3-1/2"	Poplar

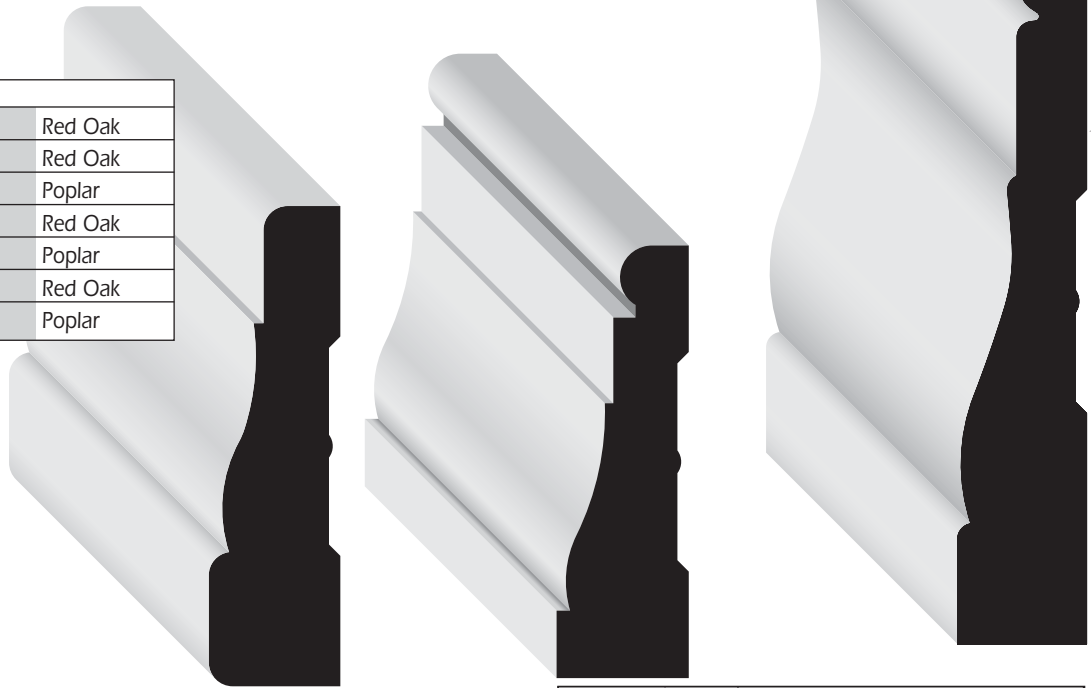

M&M#	WM#	Colonial	
351O	351	5/8" x 2-1/2"	Red Oak
L351O	LWM351	3/4" x 2-1/2"	Red Oak
L351POP	LWM351	3/4" x 2-1/2"	Poplar
356O	356	5/8" x 2-1/4"	Red Oak
356POP	356	5/8" x 2-1/4"	Poplar
L356O	356	1/2" x 2-1/4"	Red Oak
L356POP	356	1/2" x 2-1/4"	Poplar

M&M#	WM#	Beaded	
L376O	376	3/4" x 2-3/4"	Red Oak
L376POP	376	3/4" x 2-3/4"	Poplar

M&M#	WM#	Colonial	
444O	444	5/8" x 3-1/2"	Red Oak
L444O	LWM444	3/4" x 3-1/2"	Red Oak
L444POP	LWM444	3/4" x 3-1/2"	Poplar

M&M#	WM#		
L443O	443	9/16" x 2-3/4"	Red Oak
L443POP	443	9/16" x 2-3/4"	Poplar

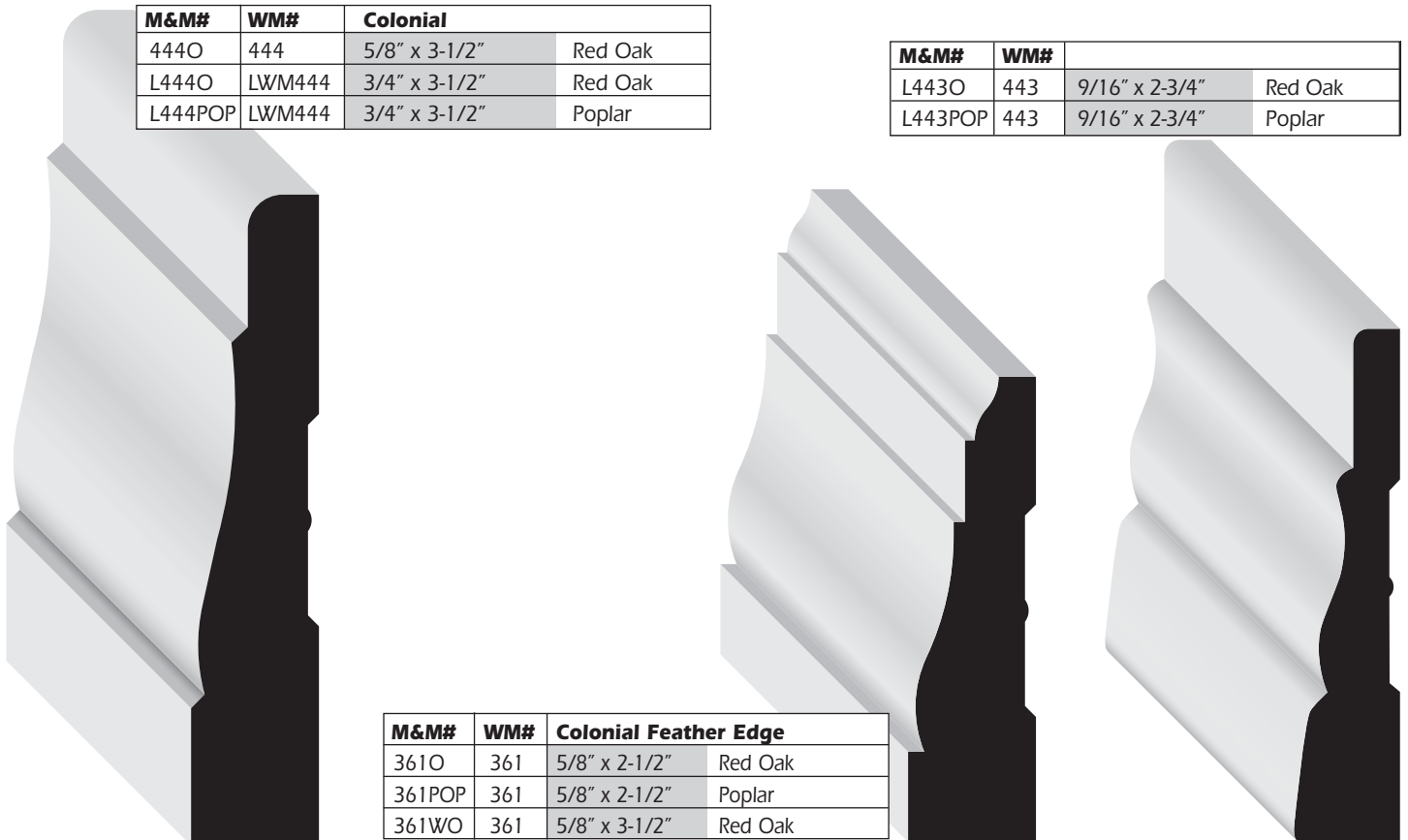

M&M#	WM#	Colonial Feather Edge	
361O	361	5/8" x 2-1/2"	Red Oak
361POP	361	5/8" x 2-1/2"	Poplar
361WO	361	5/8" x 3-1/2"	Red Oak

MOULDING & MILLWORK

Turn an ordinary room...

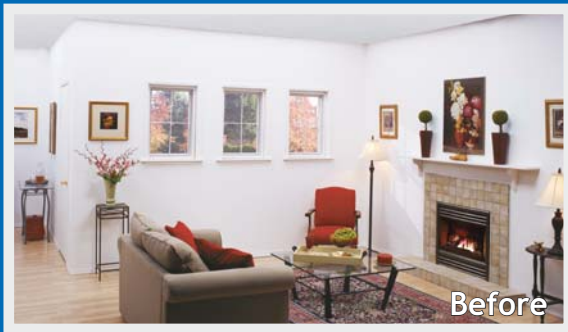

- REAL WOOD ADDS WARMTH AND BEAUTY TO ANY ROOM
- FINISHES BEAUTIFULLY
- ADDS VALUE TO YOUR HOME

into an **extraordinary** room!

STAINABLE



Providing quality products, outstanding service, innovative ideas, competitive prices and superior value.

NEW RED OAK *Signature Series*

ARCHITECTURAL MOULDINGS

Our Signature series Red Oak mouldings are precision machined and sanded on the profile face to ensure a smooth and consistent surface that will accept an even stain.

Red Oak displays a uniform magenta tint particularly evident in the heartwood. These mouldings are color sorted to be 80% heartwood.

All profiles will be full sized for architectural application.

These quality mouldings are made from the finest Northern Apalachian Oak. Moulding & Millwork stands proudly behind our product.

ARCHITECTURAL
MOULDINGS

MOULDING & MILLWORK

One company. One focus.

Visit our website www.mouldingandmillwork.com

Signature Series **New Red Oak Architectural Mouldings**

READING (PA) BRANCH

TOLL FREE: 800-537-9039
TEL: 610-404-2424
FAX: 610-404-2466

RANDOLPH (NJ) BRANCH

TOLL FREE: 888-784-9502
TEL: 973-584-0040
FAX: 973-584-0058

BALTIMORE (MD) BRANCH

TOLL FREE: 800-638-1920
TEL: 410-423-2440
FAX: 410-423-2441

BRIDGEVILLE (DE) BRANCH

TOLL FREE: 800-508-4288
TEL: 302-337-0269
FAX: 302-337-3050

MARTINSBURG (WV) BRANCH

TOLL FREE: 800-877-1797
TEL: 304-267-5900
FAX: 304-267-5597

LATROBE (PA) BRANCH

TOLL FREE: 800-737-3665
TEL: 724-537-4772
FAX: 724-537-5168

RICHMOND (VA) BRANCH

TOLL FREE: 888-391-8006
TEL: 804-530-8530
FAX: 804-530-8535

ROCHESTER (NY) BRANCH

TOLL FREE: 877-882-2424
TEL: 585-398-2633
FAX: 585-398-3386

AKRON (OH) BRANCH

TOLL FREE: 866-677-7090
TEL: 330-677-7090
FAX: 330-677-7160

South Hills Base



623BO
5/8" x 3-1/4"

North Hills Base



400
5/8" x 4-1/4"

Pittsburgh Casing



24960
3/4" x 3"

Concord Casing



10190
3/4" x 3-1/2"

Lexington Base



2620
1 1/16" x 5"

Chesapeake Base



662CO
5/8" x 3-1/2"

Piedmont Casing



444BO
3/4" x 3-1/2"

Coxcomb Casing



241120
3/4" x 3-1/2"

Virginia Base



221360
1 1/16" x 4-1/4"

Erie Base



221680
1 1/16" x 5-1/4"

Cumberland Casing



45960
3/4" x 3-1/4"

Allegheny Casing



351AO
3/4" x 2-1/2"

Plymouth Base



22160
1 1/16" x 5-5/16"

Georgetown Crown



460
3/4" x 6-1/16"

Jamestown Crown



40070
1 3/16" x 5-3/16"

Potomac Crown

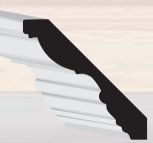

7120
1 3/16" x 4-1/2"

Hudson Crown

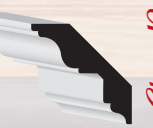

47090
3/4" x 3-9/16"

Camden Chair Rail



3000
1-1/16" x 3"

Baltimore Mullett



956WWO
7/16" x 4-1/4"

Recommended Base/Case Combos

Virginia Base / Concord Casing

221360 **10190**
1 1/16" x 4-1/4" 3/4" x 3-1/2"

Erie Base / Pittsburgh Casing

221680 **24960**
1 1/16" x 5-1/4" 3/4" x 3"

Lexington Base / Cumberland Casing

2620 **45960**
1 1/16" x 5" 3/4" x 3-1/4"

Plymouth Base / Coxcomb Casing

22160 **241120**
1 1/16" x 5-5/16" 3/4" x 3-1/2"

Chesapeake Base / South Hills Base / Allegheny Casing

662CO **623BO** **351AO**
5/8" x 3-1/2" 5/8" x 3-1/4" 3/4" x 2-1/2"

North Hills Base / Piedmont Casing

400 **444BO**
5/8" x 4-1/4" 3/4" x 3-1/2"

PROFILES SHOWN AT 20% OF ACTUAL SIZE

Product Availability

STOCK ITEMS: 1-5 Days
SPECIAL ORDER: 3-4 Weeks

MOULDING & MILLWORK

Turn an ordinary room...



Before

into an **extraordinary** room!

PAINTABLE

- COMBINE MOULDINGS TO MAKE YOUR OWN MASTERPIECES
- PRE-PRIMED - EASY TO PAINT
- FINISHES QUICK AND EASY

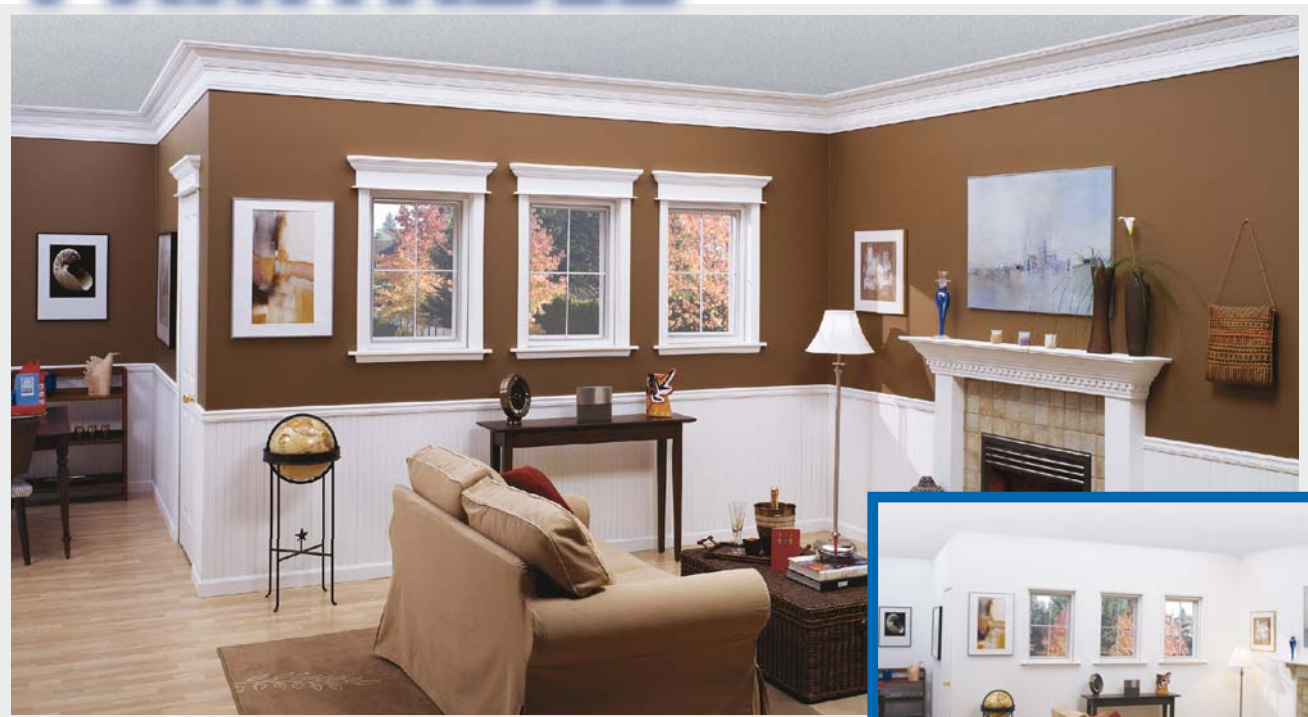

Before

Providing quality products, outstanding service, innovative ideas, competitive prices and superior value.

Casings - OAK & POPLAR

Casings define the overall character of a room and are often the most visible part of the trim. They are used primarily to cover the gap between drywall and the door or window frame. Casings are generally thicker than the base mouldings.

ALL SIZES NOMINAL

M&M#	WM#	Fluted/Reeded	
37O	37	5/8" x 3-1/4"	Red Oak
37POP	37	9/16" x 3-1/4"	Poplar

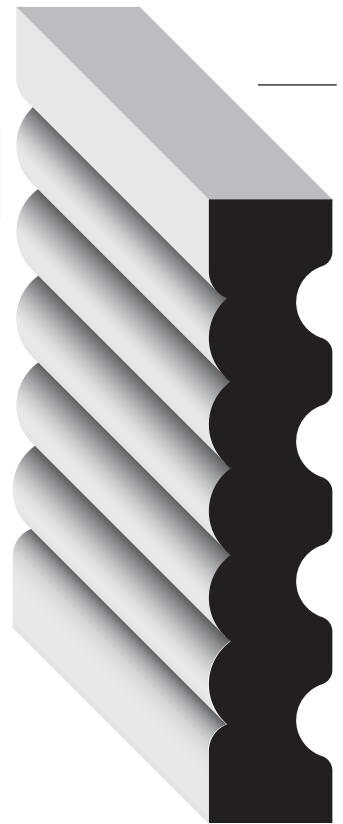

M&M#	WM#	Ranch	
327O	327	5/8" x 2-1/4"	Red Oak
327POP	327	5/8" x 2-1/4"	Poplar



Baseboards - OAK & POPLAR

Baseboards are placed along the wall at the floor. They should be chosen to work in harmony with your casings to finish and tie the room together. Baseboards are usually thinner than the casing.

ALL SIZES NOMINAL

M&M#	WM#	O.G.	
662POP	662	1/2" x 3-1/2"	Poplar
662O	662	1/2" x 3-1/2"	Red Oak
L663POP	663	5/8" x 3-1/2"	Poplar
L663O	663	5/8" x 3-1/2"	Red Oak



M&M#	WM#		
L664O	LWM664	3/8" x 3"	Red Oak
L664POP	LWM664	3/8" x 3"	Poplar
L664WO	LWM664	3/8" x 4"	Red Oak
L664WPO	LWM664	3/8" x 4"	Poplar

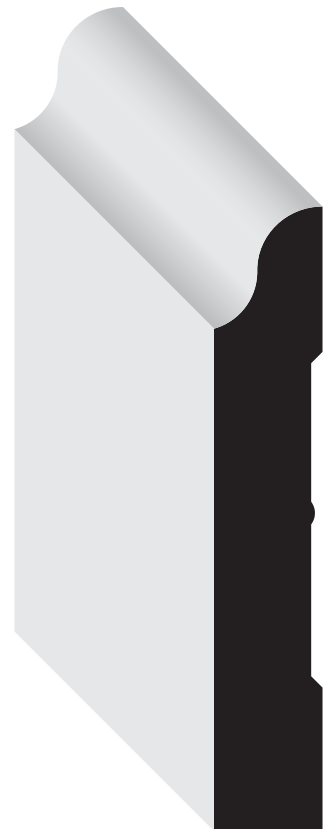
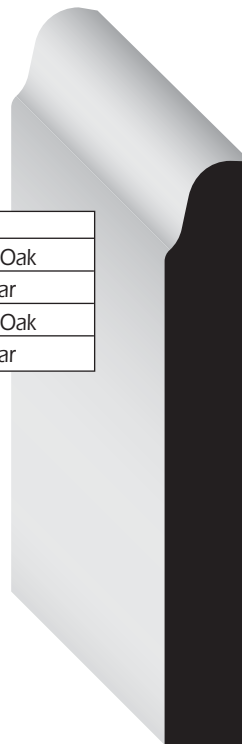

M&M#	WM#	Tear Drop	
714O	714	1/2" x 3"	Red Oak
714POP	714	1/2" x 3"	Poplar

Baseboards - OAK & POPLAR

Baseboards are placed along the wall at the floor. They should be chosen to work in harmony with your casings to finish and tie the room together. Baseboards are usually thinner than the casing.

ALL SIZES NOMINAL

M&M#	WM#	Colonial
L263EO	263E	1 1/16" x 5-1/2" Red Oak
L263EPOP	263E	1 1/16" x 5-1/2" Poplar

M&M#	WM#	Colonial
L163EO	163	1 1/16" x 4-1/2" Red Oak
L163EPOP	163	1 1/16" x 4-1/2" Poplar
8382O		1 1/16" x 5-1/2" Red Oak
8382POP		1 1/16" x 5-1/2" Poplar

M&M#	WM#	
753WO	LWM753	7/16" x 4" Red Oak
753WPOP	LWM753	7/16" x 4" Poplar

M&M#	WM#	O.G.
620O	620	1/2" x 4-1/4" Red Oak
620POP	620	1/2" x 4-1/4" Poplar
622O	622	1/2" x 3-1/2" Red Oak
622POP	622	1/2" x 3-1/2" Poplar
624O	624	1/2" x 3" Red Oak
624POP	624	1/2" x 3" Poplar
L624O	LWM624	3/8" x 3" Red Oak
L624POP	LWM624	3/8" x 3" Poplar

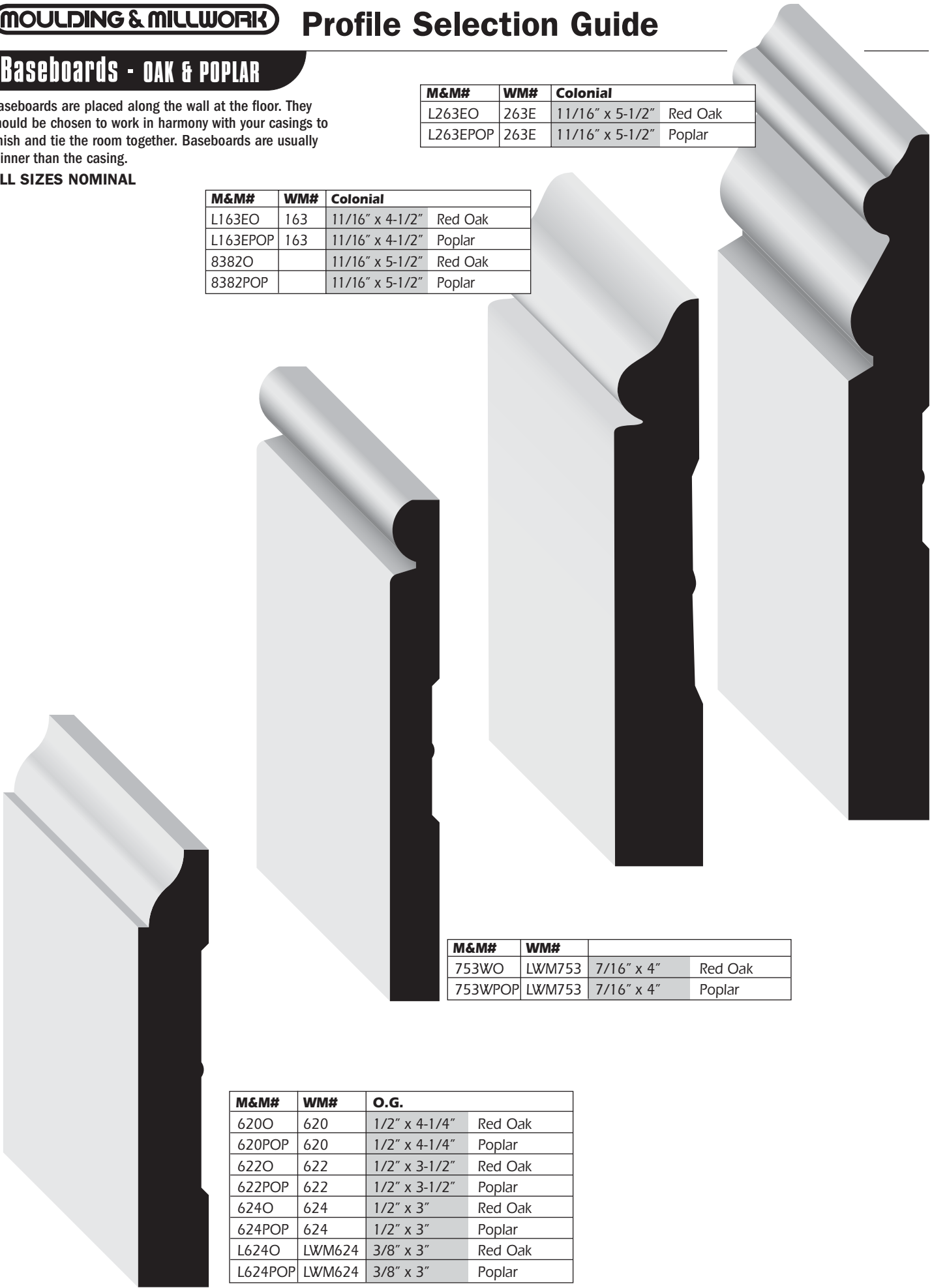

Crowns - OAK & POPLAR

Crowns are placed along the wall at the ceiling. They come in a wide range of patterns and sizes. Crowns soften the transition from wall to ceiling while adding a distinctive look and charm to your room.

ALL SIZES NOMINAL

M&M#	WM#	Crown	
L45O	45	3/4" x 5-1/4"	Red Oak
L45POP	45	3/4" x 5-1/4"	Poplar

M&M#	WM#	Crown	
L47O	47	3/4" x 4-5/8"	Red Oak
L47POP	47	3/4" x 4-5/8"	Poplar

M&M#	WM#	Crown	
L49O	49O	3/4" x 3-5/8"	Red Oak
L49POP	49POP	3/4" x 3-5/8"	Poplar

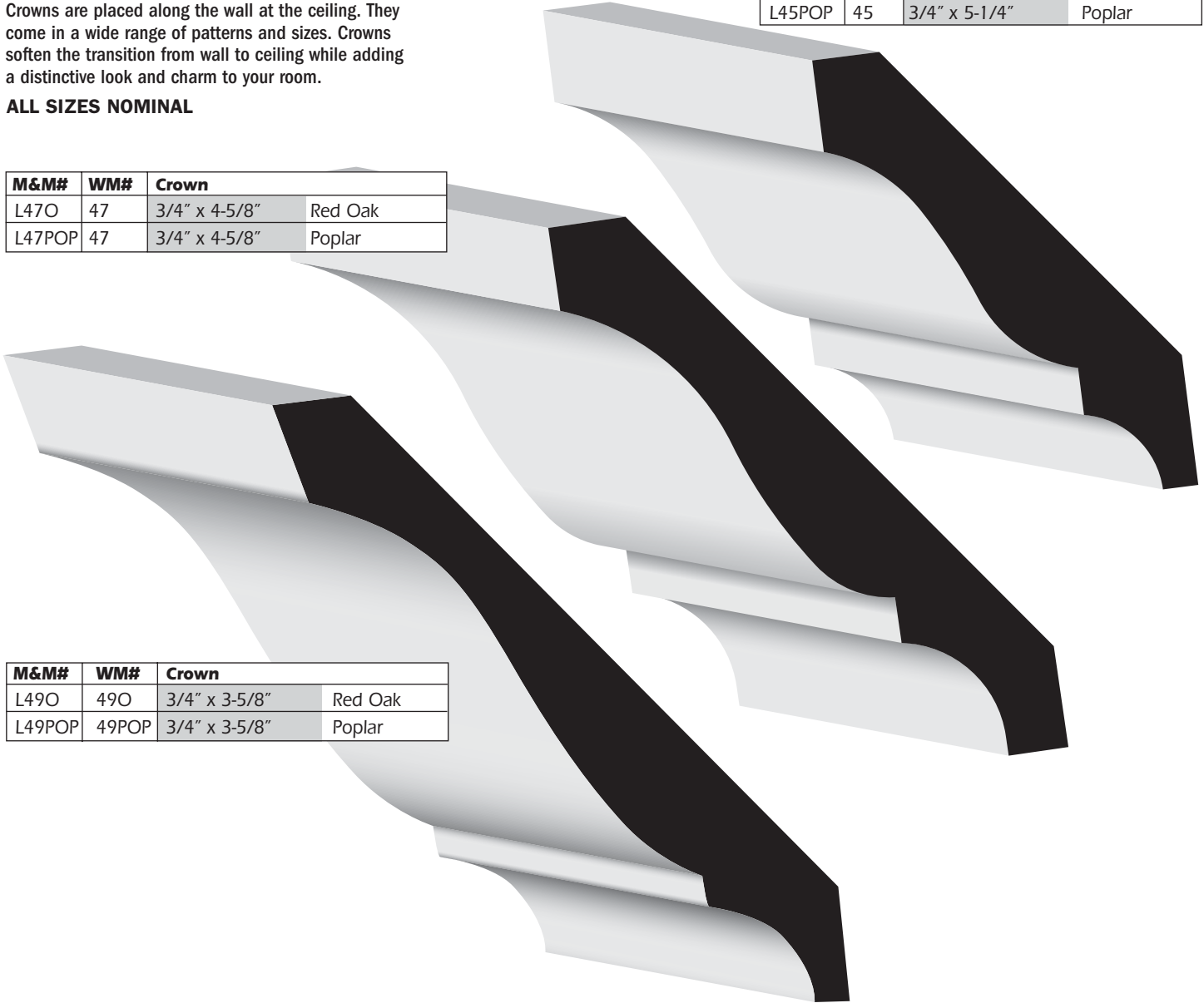

Door Stops & Battens - OAK & POPLAR

Stops are attached to the door jamb on both sides and at the top. It is where the door comes to a rest when it is closed stopping the door from moving any further, and covering the gap that would otherwise appear between the door and the jambs.

ALL SIZES NOMINAL

M&M#	WM#	Round Edge	
885POP	885	3/8" x 1-5/8"	Poplar

M&M#	WM#	Colonial	
907O	907	7/16" x 1-1/4"	Red Oak
907POP	907	7/16" x 1-1/4"	Poplar

M&M#	WM#	Colonial	
947O	947	3/8" x 1-1/4"	Red Oak
947POP	947	3/8" x 1-1/4"	Poplar

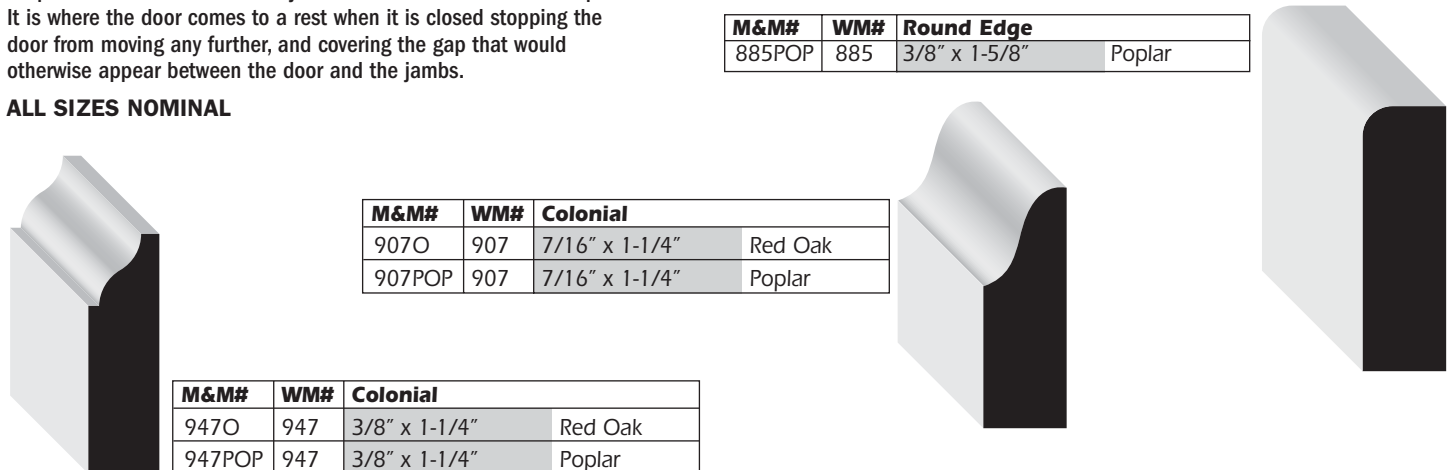

Chair Rails - OAK & POPLAR

Chair Rails are practical as well as decorative. Applied to a wall, anywhere from 24 to 48 inches from the floor, they protect the wall from scuffs and dents from the backs of chairs as well as adding a beautiful accent to any room.

ALL SIZES NOMINAL

M&M#	WM#	Chair Rail	
CR3O	3	1" x 3-1/2"	Red Oak
CR3POP	3	1" x 3-1/2"	Poplar

M&M#	WM#	Chair Rail	
394WO	394W	3/4" x 2-1/2"	Red Oak
394WPOP	394W	3/4" x 2-1/2"	Poplar



M&M#	WM#	Chair Rail	
394O	394	3/4" x 2-3/8"	Red Oak
394POP	394	3/4" x 2-3/8"	Poplar

M&M#	WM#	Chair Rail	
390O	390	5/8" x 2-5/8"	Red Oak
390POP	390	11/16" x 2-5/8"	Poplar

Panel Mouldings - OAK & POPLAR

Panel moulds are used to frame wall paneling and add a decorative element to this type of application. Panel moulds also add accent to walls.

ALL SIZES NOMINAL

M&M#	WM#	Base Cap	
166O	166	5/8" x 1-1/4"	Red Oak
166POP	166	5/8" x 1-1/4"	Poplar



M&M#	WM#	Base Cap	
L167O	167	5/8" x 1-1/4"	Red Oak
L167POP	167	5/8" x 1-1/4"	Poplar



M&M#	WM#	Base Cap	
163O	163	5/8" x 1-3/8"	Red Oak
163POP	163	5/8" x 1-3/8"	Poplar

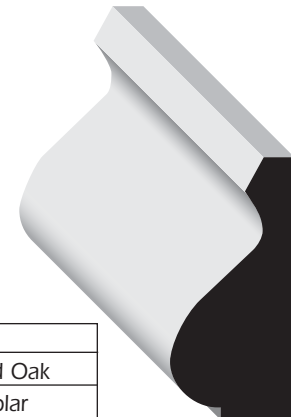

Lattice - OAK & POPLAR

Lattice is a thin strip of flat moulding commonly used to hide seams and trim edges. They are available in a multitude of widths and are useful for a wide variety of projects

ALL SIZES NOMINAL

M&M#	WM#	Lattice	
265O	265	1/4" x 1-3/4"	Red Oak
265WO	265	1/4" x 2-1/2"	Red Oak
265WPOP	265	1/4" x 2-1/2"	Poplar
266WO	266	1/4" x 1-5/8"	Red Oak
266WPOP	266	1/4" x 1-5/8"	Poplar

M&M#	WM#	Lattice	
BAL5.5O	5.5	1/4" x 5-1/2"	Red Oak
BAL5.5POP	5.5	1/4" x 5-1/2"	Poplar



Quarter Rounds & Shoes - OAK & POPLAR

Quarter Rounds come in several sizes and serve a variety of functions. However, they are most often used to finish inside corners.

Shoes are primarily used to trim flooring materials and are often used in combination with a traditional baseboard to conceal variations between the flooring and the base.

ALL SIZES NOMINAL

M&M#	WM#	Quarter Round	
106O	106	11/16" x 11/16"	Red Oak
106POP	106	11/16" x 11/16"	Poplar

M&M#	WM#	Shoes	
126O-A	126	1/2" x 3/4"	Red Oak
126POP	126	1/2" x 3/4"	Poplar

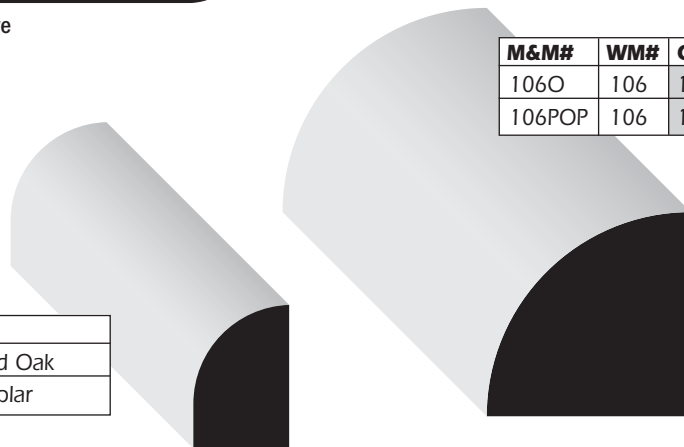

Coves - OAK & POPLAR

This profile is commonly used to soften the transition on inside corners but may be used for a wide range of applications.

ALL SIZES NOMINAL

M&M#	WM#	Cove	
86BO	86	11/16" x 1-3/4"	Red Oak
86BPOP	86	11/16" x 1-3/4"	Poplar

M&M#	WM#	Cove	
93O	93	3/4" x 3/4"	Red Oak
93POP	93	3/4" x 3/4"	Poplar



Mullions - OAK & POPLAR

Mullion casing or batten—these profiles are combined with other mouldings to create a decorative chair rail application.

ALL SIZES NOMINAL

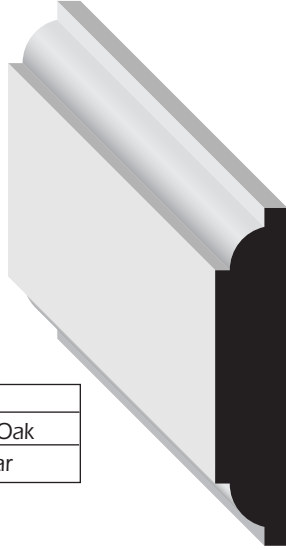

M&M#	WM#	Mullion	
978O	978	3/8" x 1-3/4"	Red Oak
978POP	978	3/8" x 1-3/4"	Poplar

Corners - OAK & POPLAR

This profile is used to protect the outside edges from damage and abrasion. Outside corners come in a wide variety of sizes and detailing.

ALL SIZES NOMINAL



M&M#	WM#	Round Edge	
205O	205	1-1/8" x 1-1/8"	Red Oak
205POP	205	1-1/16" x 1-1/16"	Poplar
206O	206	3/4" x 3/4"	Red Oak
206POP	206	3/4" x 3/4"	Poplar

Hand & Wall Rails - OAK & POPLAR

Handrails provide safety and support while going up or down stairs.

ALL SIZES NOMINAL

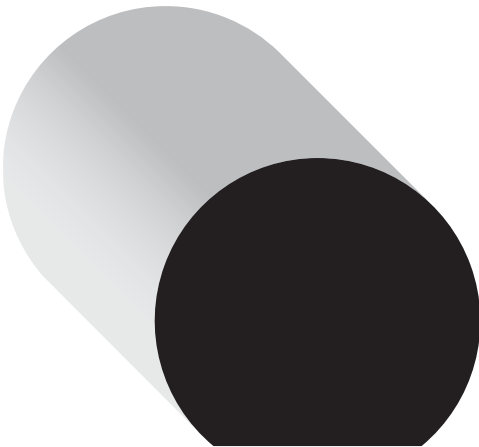

M&M#	WM#	Oval	
230O	230	1-3/8" x 1-11/16"	Red Oak
230POP	230	1-3/8" x 1-11/16"	Poplar

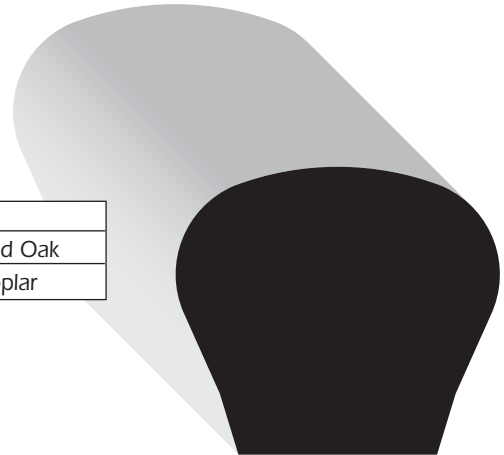

M&M#	WM#	Oval	
240POP	240	1-1/8" x 2-1/4"	Poplar

M&M#	WM#	Round	
231POP	231	1-3/8" x 1-11/16"	Poplar



Misc. Profiles - OAK & POPLAR

ALL SIZES NOMINAL

M&M#	WM#	Tilt Stool	
8672O	8672	11/16" x 2-1/2"	Red Oak
8672POP	8672	11/16" x 2-1/2"	Poplar

M&M#	WM#	Oak Landing Tread	
1060O	1060	1-1/16" x 3-1/2"	Red Oak
1060POP	1060	1-1/16" x 3-1/2"	Poplar
1060W	1060	1-1/16" x 5-1/2"	Red Oak
1060WPOP	1060	1-1/16" x 5-1/2"	Poplar



M&M#	WM#	Bed Moulding	
L75O	75	3/4" x 1-3/4"	Red Oak
L75POP	75	3/4" x 1-3/4"	Poplar

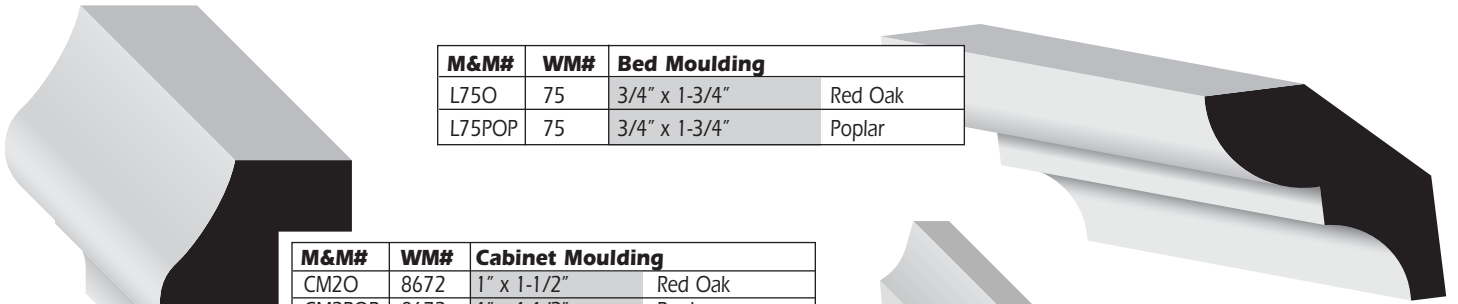

M&M#	WM#	Cabinet Moulding	
CM2O	8672	1" x 1-1/2"	Red Oak
CM2POP	8672	1" x 1-1/2"	Poplar

M&M#	WM#	Scotia	
1075O	1075	1/2" x 3/4"	Red Oak
1075POP	1075	1/2" x 3/4"	Poplar

Casings - ULTRALITE MDF

Casings define the overall character of a room and are often the most visible part of the trim. They are used primarily to cover the gap between drywall and the door or window frame. Casings are generally thicker than the base mouldings.

ALL SIZES NOMINAL

M&M#	WM#	Colonial	
356M	356	15mm x 2-1/4"	Ultralite MDF

M&M#	WM#	Colonial	
444M	444	18mm x 3-1/2"	Ultralite MDF

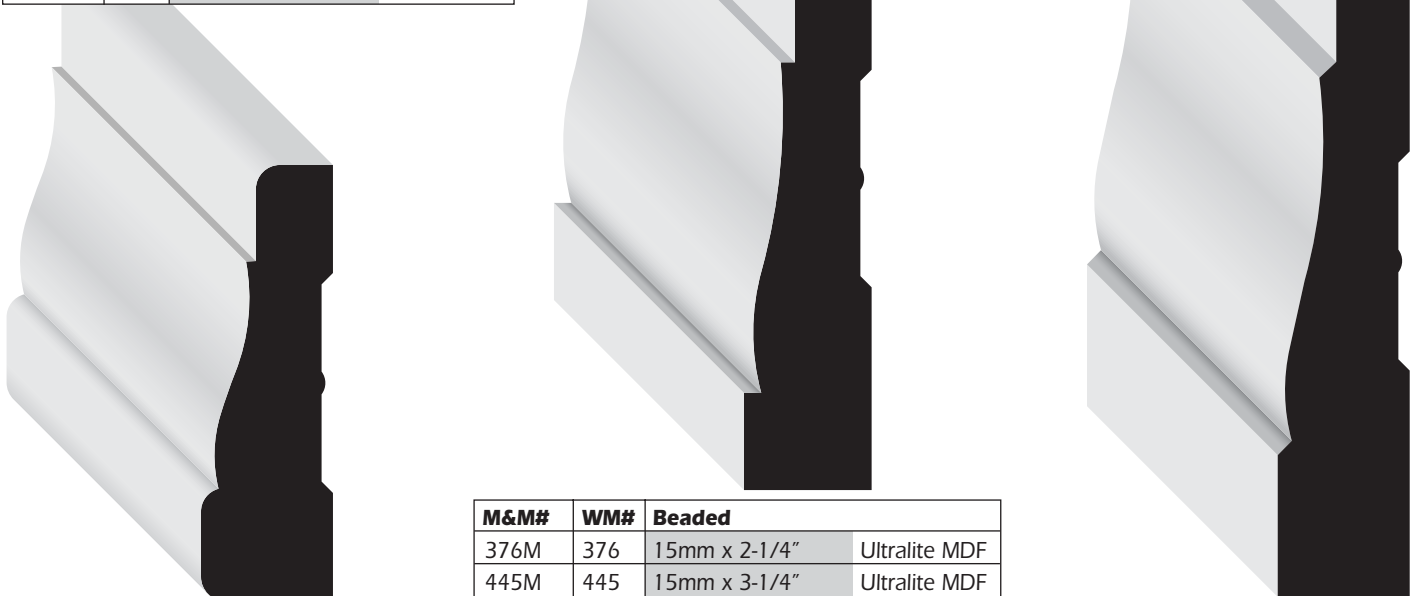

M&M#	WM#	Beaded	
376M	376	15mm x 2-1/4"	Ultralite MDF
445M	445	15mm x 3-1/4"	Ultralite MDF

Casings - ULTRALITE MDF

Casings define the overall character of a room and are often the most visible part of the trim. They are used primarily to cover the gap between drywall and the door or window frame. Casings are generally thicker than the base mouldings.

ALL SIZES NOMINAL

M&M#	WM#		
411M	411	18mm x 3"	Ultralite MDF



M&M#	WM#		
535M	535	18mm x 3-1/2"	Ultralite MDF



M&M#	WM#		
8063M	8063	18mm x 3/4"	Ultralite MDF



M&M#	WM#	Colonial Feather Edge	
361M	361	15mm x 2-1/2"	Ultralite MDF
361WM	361	15mm x 3-1/2"	Ultralite MDF

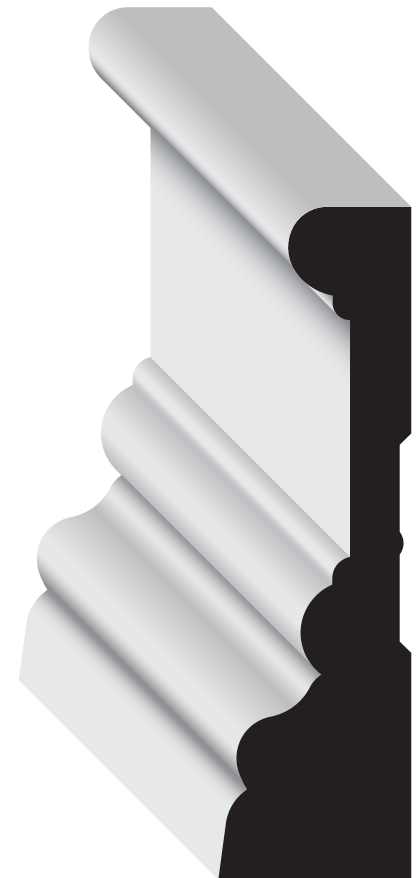
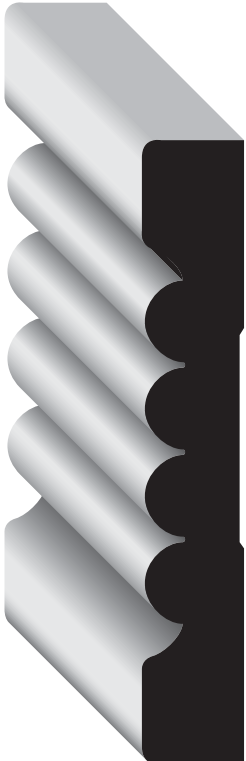

M&M#	WM#		
908M	908	15mm x 3-1/4"	Ultralite MDF

M&M#	WM#	Architrave	
RB3M	RB3	25mm x 3-1/2"	Ultralite MDF

Baseboards - ULTRALITE MDF

Baseboards are placed along the wall at the floor. They should be chosen to work in harmony with your casings to finish and tie the room together. Baseboards are usually thinner than the casing.

ALL SIZES NOMINAL

M&M#	WM#		
8263M	8263	15mm x 6-1/2"	Ultralite MDF

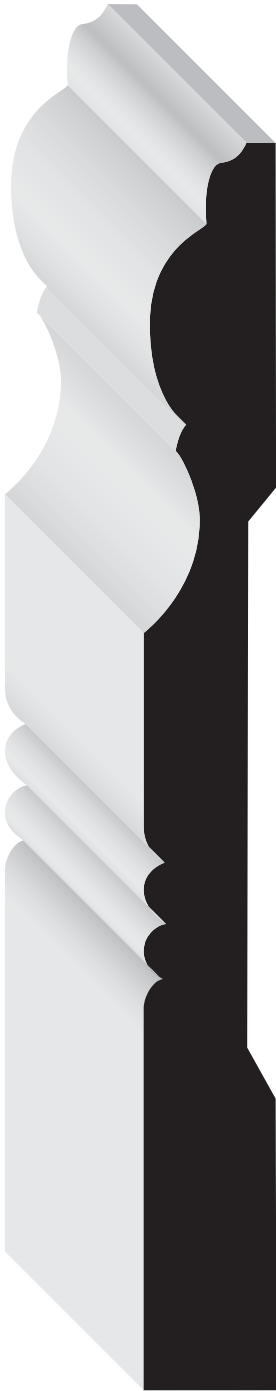

M&M#	WM#		
412M	412	15mm x 4-1/4"	Ultralite MDF



M&M#	WM#	Speed Base	
163EM7	163	15mm x 7-1/4"	Ultralite MDF
163EM	163	15mm x 5-1/4"	Ultralite MDF

Baseboards - ULTRALITE MDF

Baseboards are placed along the wall at the floor. They should be chosen to work in harmony with your casings to finish and tie the room together. Baseboards are usually thinner than the casing.

ALL SIZES NOMINAL

M&M#	WM#	O.G.	
623M	623	12mm x 3-1/4"	Ultralite MDF
620M	620	12mm x 4-1/4"	Ultralite MDF

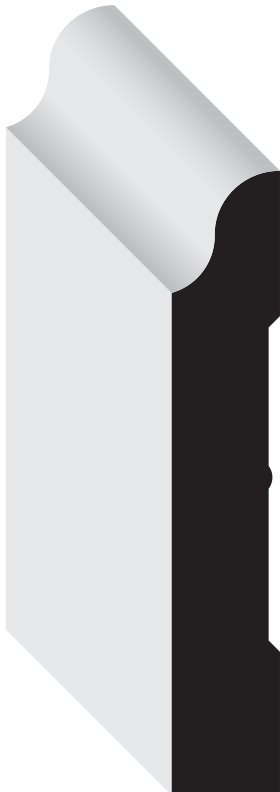

M&M#	WM#		
545M	545	15mm x 5"	Ultralite MDF

M&M#	WM#		
662M	662	12mm x 3-1/2"	Ultralite MDF
663M	663	12mm x 3-1/4"	Ultralite MDF

Crowns - ULTRALITE MDF

Crowns are placed along the wall at the ceiling. They come in a wide range of patterns and sizes. Crowns soften the transition from wall to ceiling while adding a distinctive look and charm to your room.

ALL SIZES NOMINAL

M&M#	WM#	Crown
49M	49M	15mm x 3-5/8" Ultralite MDF

M&M#	WM#	Crown
47M	47	15mm x 4-5/8" Ultralite MDF

M&M#	WM#	Crown
43M	43	25mm x 6-15/16" Ultralite MDF

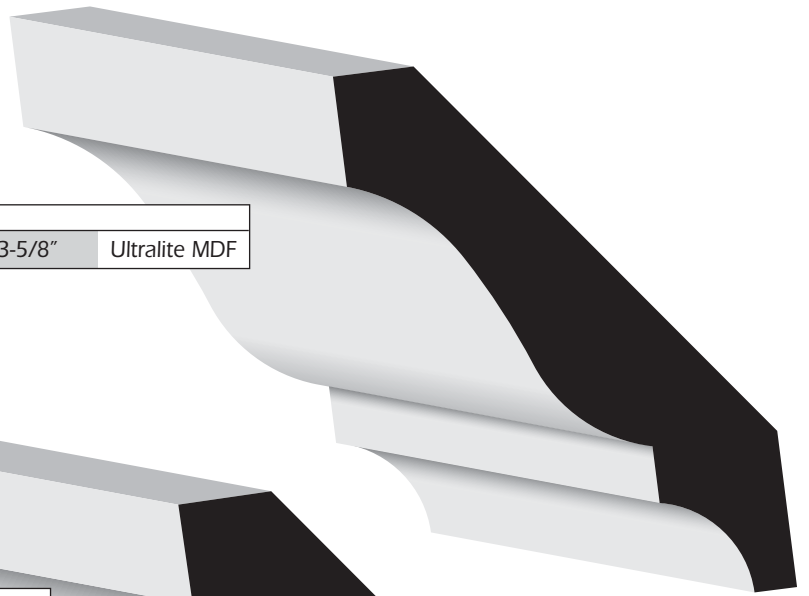

Crowns - ULTRALITE MDF

Crowns are placed along the wall at the ceiling. They come in a wide range of patterns and sizes. Crowns soften the transition from wall to ceiling while adding a distinctive look and charm to your room.

ALL SIZES NOMINAL

M&M#	WM#	Crown	
712M	712	18mm x 4-1/2"	Ultralite MDF

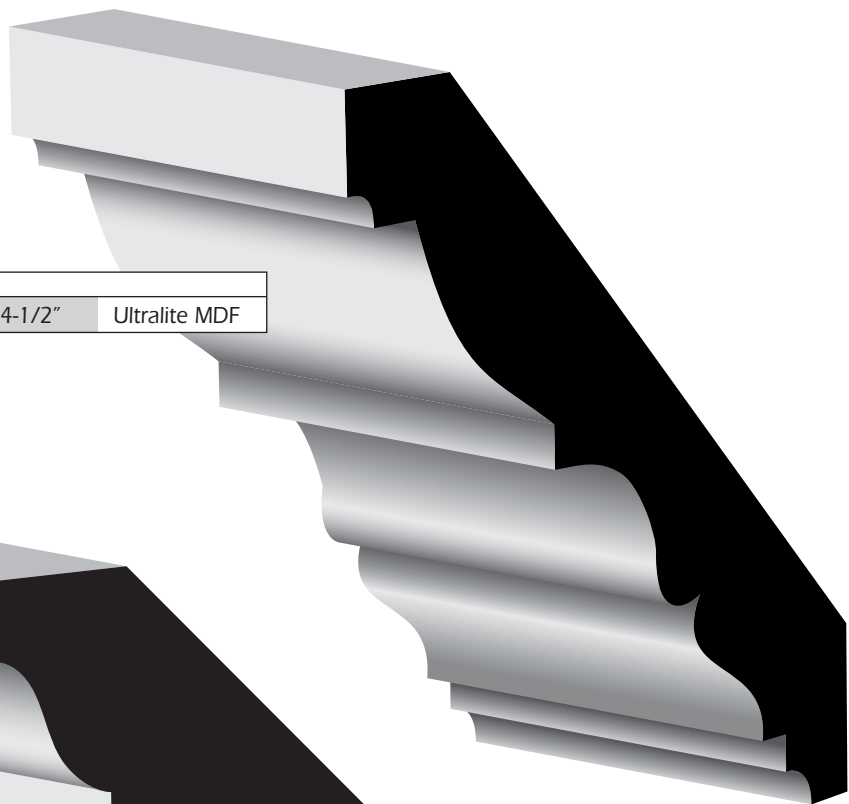

M&M#	WM#	Crown	
41M	41	30mm x 6-5/16"	Ultralite MDF



M&M#	WM#	Crown	
45M	45M	15mm x 5-1/4"	Ultralite MDF

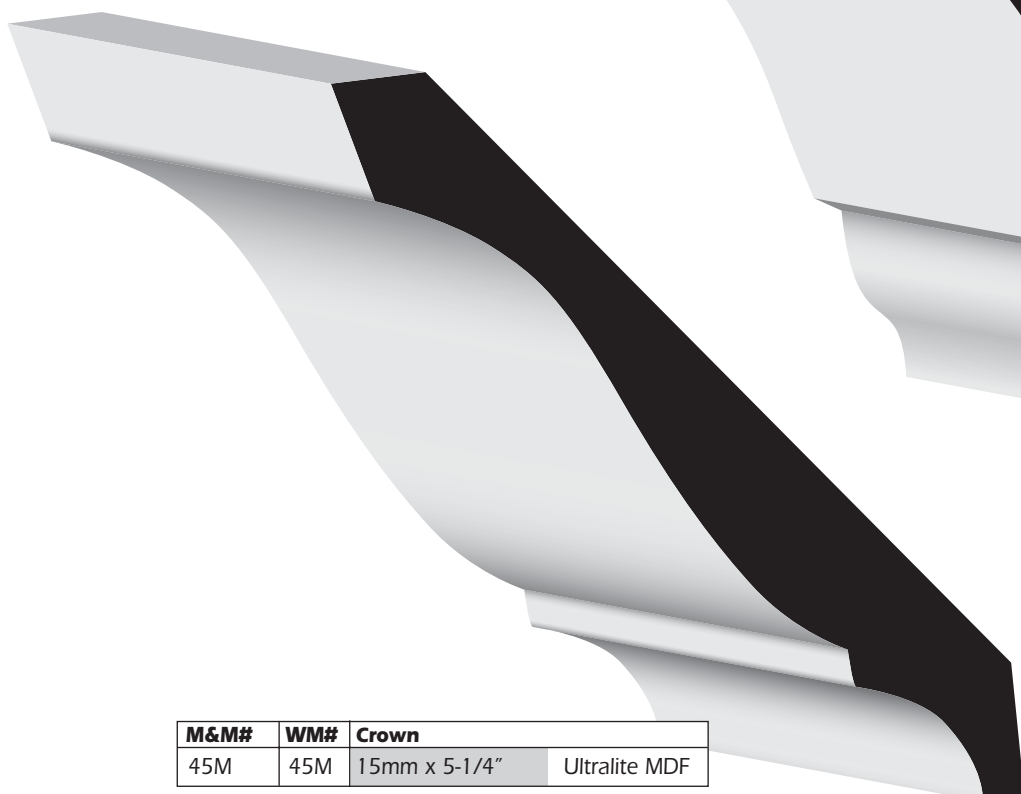

Chair Rails - ULTRALITE MDF

Chair Rails are practical as well as decorative. Applied to a wall, anywhere from 24 to 48 inches from the floor, they protect the wall from scuffs and dents from the backs of chairs as well as adding a beautiful accent to any room.

ALL SIZES NOMINAL



M&M#	WM#	Chair Rail	
297M	297	15mm x 3"	Ultralite MDF

Brickmoulds - PVC

A Brickmould is used as exterior casing around doors. 2 inches is the most common size, however, 1-1/2 and 1-1/4 inch sizes are available.

ALL SIZES NOMINAL



M&M#	WM#	Brickmould	
PVC180	180	1-1/4" x 2"	PVC

Squares - FIR

Squares and Parting Beads are used in a wide range of applications including the filling of gaps and height transitions. This profile may also be used in a variety of craft projects.

ALL SIZES NOMINAL

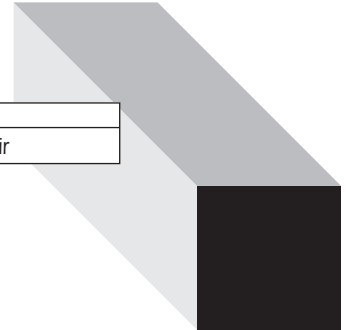

M&M#	WM#	Baluster - E4E	
237	237	1-1/4" x 1-1/4"	Fir

Hand & Wall Rails - FIR

Handrails provide safety and support while going up or down stairs.

ALL SIZES NOMINAL

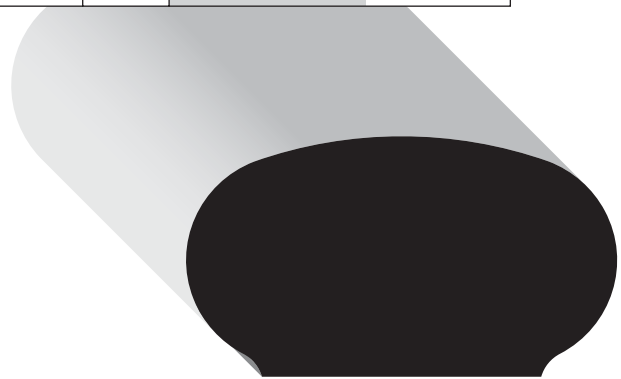

M&M#	WM#	Oval	
240	240	1-1/4" x 2-1/4"	Fir

M&M#	WM#	Oval	
230	230	1-1/2" x 1-11/16"	Fir

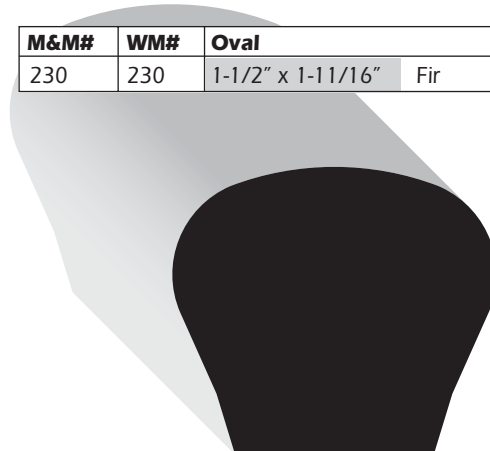

Misc. Profiles - FIR

ALL SIZES NOMINAL

M&M#	WM#	T-Astragal
1305	1305	1-3/8" Door Fir

M&M#	WM#	Closest Pole - Round
232	232	1-9/16" Fir
233	233	1-5/16" Fir

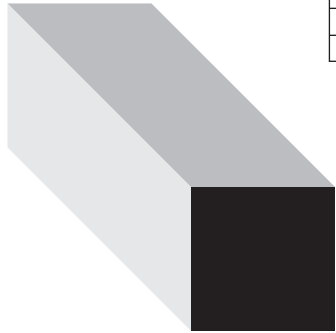

M&M#	WM#	S4S Baluster
237	237	1-1/4" x 1-1/4" Fir

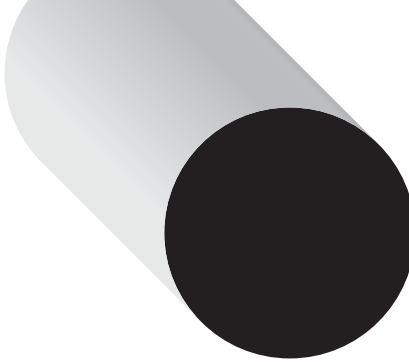

Finish Boards (S4S)

ALL SIZES NOMINAL

Finish boards come in either S4S (surfaced four sides) or S3S (surfaced 3 sides) and are used for a multitude of purposes including shelving, window liner, bases, casing, etc.

- Red Oak
- Pine Boards
- Primed Finger Joint
- Primed MDF
- Poplar
- PVC

	1x2	1x4	1x6	1x8	1x10	1x12	5/4x6	5/4x8	5/4x10	5/4x12
PRIMED FJ		X	X	X	X	X				
PRIMED MDF		X	X	X	X	X				
SOLID PINE		X	X	X	X	X				
RED OAK	X	X	X	X	X	X				
POPLAR	X	X	X	X	X	X				
PVC		X	X	X	X	X	X	X	X	X

Oak and Poplar Boards are available in loose Random mix:

and

Factory Wrapped 500 Board Foot packs
 ▪ Random mix 6 - 16 Ft.

and

Factory Wrapped 250 Board Foot long packs
 ▪ Random mix 12 - 16 Ft.

Interior Jambs

ALL SIZES NOMINAL

Interior Jambs all dadoed at 81" below dado.

	4-9/16 x 6/8
SOLID PINE	X
PINE VENEER	X
FINGER JOINT PINE	X
PRIMED FJ PINE	X
OAK VENEER	X
POPLAR VENEER	X
SOLID OAK	X
SOLID POPLAR	X

Jambs are available in Sublift, Full lift & multiple lift quantities. Please call for current market pricing.

Glossary of Terms

- BASEBOARDS:** Baseboards are placed along the wall at the floor. They should be chosen to work in harmony with your casings to finish and tie the room together. Baseboards are usually thinner than the casing.
- BASE SHOES:** Base shoes are primarily used to trim flooring materials and are often used in combination with a traditional baseboard to conceal variations between the flooring and the base. However, this versatile profile works great to solve numerous trimming needs.
- BEADED CEILING:** A popular profile used often as wainscot paneling. Combined with a chair rail or cap mould and a baseboard, beaded ceiling makes a distinctive wainscot package.
- BRICKMOULDS:** A Brickmould is used as exterior casing around doors. 2 inches is the most common size, however, 1-1/2 and 1-1/4 inch sizes are available.
- BUILD-UPS:** Combining two or more moulding profiles to create a new or custom look. Also called stacking, build-ups make it easy to create the look of custom made trimwork without the high cost.
- BULLNOSE:** A term used to describe the eased edges of trim and stops. A single bull nose stop would have one eased edge and a square edge back. A double bull nose stop would have two eased edges.
- CASING:** Casings define the overall character of a room and are often the most visible part of the trim. They are used primarily to cover the gap between drywall and the door or window frame. Casings are generally thicker than the base mouldings.
- CHAIR RAILS:** Chair Rails are practical as well as decorative. Applied to a wall, anywhere from 24 to 48 inches from the floor, they protect the wall from scuffs and dents from the backs of chairs as well as adding a beautiful accent to any room.
- CORNERS:** Corners are used to protect the outside edges from damage and abrasion. Outside corners come in a wide variety of sizes and detailing.
- COVES:** Coves are commonly used to soften the transition on inside corners but may be used for a wide range of applications.
- CROWNS:** Crowns are placed along the wall at the ceiling. They come in a wide range of patterns and sizes. Crowns soften the transition from wall to ceiling while adding a distinctive look and charm to your room.
- DENTIL:** A moulding pattern with a series of closely spaced rectangular blocks and spaces. Used especially in classic architecture.
- FINISH BOARDS:** Finish boards come in either S4S (surfaced four sides) or S3S (surfaced three sides) and are used for a multitude of purposes including shelving, window liner, bases, casing, etc.
- FULL ROUNDS:** Full rounds are used for numerous purposes and projects. Some of the more common uses are closet poles, curtain rods and towel rods.
- HALF ROUNDS:** A cross section of this profile looks like a half circle and is used primarily as decorative trim. It works well as a trim piece for wall paper or to add a decorative pattern to flat panels. This profile can also be used to put a rounded edge on various shelving.
- HANDRAILS:** Handrails provide safety and support while going up or down stairs.
- LATTICE:** A lattice is a thin strip of flat moulding commonly used to hide seams and trim edges. They are available in a multitude of widths and are useful for a wide variety of projects.
- PANEL MOULDS:** Panel moulds are used to frame wall paneling and add a decorative element to this type of application. Panel moulds also add accent to walls.
- QUARTER ROUNDS:** Quarter Rounds come in several sizes and serve a variety of functions. However, they are most often used to finish inside corners.
- RETURN:** Term used to indicate the method of carrying a mouldings detail from the front of the moulding back to the wall. Generally a 45 degree cut is made to the front of the long moulding and an opposite 45 is cut on a small piece to carry the detail to the wall.
- SCREEN MOULD:** A very versatile profile; screen mould fits a wide variety of needs and uses. Traditionally used to hold mesh screening into wood screens, it also works well as edge trim on $\frac{3}{4}$ " shelving or wood trim for wall paper etc.
- SQUARES AND PARTING BEADS:** Squares and Parting Beads are used in a wide range of applications including filling gaps and transitioning heights. This profile may also be used in a variety of craft projects.
- STOPS:** A stop is attached to the door jamb on both sides and at the top. It is where the door comes to a rest when it is closed, stopping the door from moving any further, and covering the gap that would otherwise appear between the door and the jambs.
- WAINSCOTING:** Trimwork installed in the area below a chair rail. Numerous options are available including raised panel, shadow box and beaded ceiling. Combined with a chair rail and baseboard wainscoting creates a dramatic look to any room.
- WINDOW CASING:** Trim that borders the edges of a window frame. Casings define the overall character of the room and are often the most visible part of the trim.
- WINDOW STOOL:** The surface installed below the sash of a window. Also called window sill. Trim installed under window stool creates a distinctive look and adds a decorators touch.

Storage, Handling and Preparation of all Mouldings and S4S Boards

Until the time this product has been correctly **final coated (after painting or staining)** and installed, in conformance with all paint manufacturer recommendations as well as the highest and best building practices, respectively, for intended use, it must be **continuously and effectively protected from exposure to direct sunlight, ground contact and the elements**. It should be **stored only in a dry, clean location and transported only if fully protected from water**. As a final preparation before installation: **(a) indoors**, the product **must be "acclimated" to the environment by storing it in the installation space for at least 3 days** (with both faces exposed to the air in that space); **(b) outdoors**, **every surface lacking both primer and final coat must be effectively coated** to achieve protection recommended by the paint manufacturer respecting intended use.